

# Values-Based Innovation

*Designing a Model to be applied  
in Management Sciences*



JUAN MEJÍA TREJO  
ÁNGEL RODRÍGUEZ BRAVO

Universidad de Guadalajara  
Universidad Autónoma de Barcelona





# VALUES-BASED INNOVATION

Designing a Model to be applied  
in Management Sciences



# VALUES-BASED INNOVATION

Designing a Model to be applied  
in Management Sciences

JUAN MEJÍA TREJO  
ÁNGEL RODRÍGUEZ BRAVO

Universidad de Guadalajara  
Universidad Autónoma de Barcelona

Este libro fue sometido a un proceso de dictamen por pares  
de acuerdo con las normas establecidas por el Comité  
Editorial del Centro Universitario de Ciencias Económico  
Administrativas de la Universidad de Guadalajara

Primera edición 2019

D.R. © 2019, Universidad de Guadalajara  
Centro Universitario de Ciencias  
Económico Administrativas  
Periferico Norte No. 779  
Núcleo Universitario Los Belenes  
Zapopan Jalisco, C.P. 45100

**ISBN: 978-84-17840-36-5**

**<https://doi.org/10.55965/abib.9788417840365.2019b>**

Impreso y hecho en México *Printed and made in México*

# Contenido

Introduction . . . . .	9
Chapter 1. The importance of values in management sciences . . . . .	11
1.1. <i>Some studies of values in the management sciences</i> . . . . .	11
1.2. <i>Importance of the values</i> . . . . .	18
1.3. <i>Managers and values.</i> . . . . .	20
1.4. <i>The Values-based management</i> . . . . .	21
1.4.1. <i>Productivity</i> . . . . .	24
1.4.2. <i>Effectiveness and Efficiency</i> . . . . .	25
1.5. <i>Values vs. Value-based management</i> . . . . .	27
1.6. <i>Management by values</i> . . . . .	30
1.7. <i>The organizations and categories of values</i> . . . . .	33
1.8. <i>How to weight and determine a value?</i> . . . . .	36
1.8.1. <i>Evaluation of values protocol (Introducing the <b>EVA</b> protocol)</i> . . . . .	37
1.8.2. <b>EVA protocol.</b> <i>How to weight a value.</i> . . . . .	37
Chapter 2. The relationship between values and innovation . . . . .	40
2.1. <i>Values type in innovation management</i> . . . . .	40
2.2. <i>Innovation Management</i> . . . . .	42
2.3. <i>The utility of relating values with innovation</i> . . . . .	44
2.4. <i>Values-based innovation as a platform of the strategy</i> . . . . .	47
2.5. <i>Values-based innovation results due its relationships</i> . . . . .	49
2.6. <i>Values-based innovation and how is applied in the firm or corporate organization</i> . . . . .	52
2.7. <i>Values-based innovation and other similar terms</i> . . . . .	56
2.9. <i>Values-based innovation and the integrative function operation</i> . . . . .	59
2.10. <i>Values-based innovation and open innovation</i> . . . . .	60
2.10.1. <i>Innovation Ecosystem (IEC).</i> . . . . .	61
2.10.2. <i>Open Business Model (OBM)</i> . . . . .	62
2.10.3. <i>Knowledge Management (KMG)</i> . . . . .	64



Chapter 3. A general conceptual model proposal . . . . .	65
3.1. <i>How does it work?</i> . . . . .	68
3.2. <b>EVA protocol</b> where valuing starts . . . . .	70
3.2.1. <i>Selecting the values for inventory</i> . . . . .	71
3.2.2. <i>Determining the values</i> . . . . .	72
3.2.3. <i>The designing of protocol to assess and measure the values.</i> . . . . .	73
3.2.4. <i>Qualitative validation of the protocol to assess</i> <i>and measure the values.</i> . . . . .	73
3.2.5. <i>Designing the test</i> . . . . .	75
3.2.6. <i>Validating the tool</i> . . . . .	76
3.2.7. <i>The test contrast</i> . . . . .	76
3.2.8. <i>Results.</i> . . . . .	77
3.2.9. <i>Power of value: graphic analysis</i> . . . . .	86
3.2.10. <i>Global load of value analysis</i> . . . . .	87
3.2.11. <i>Dominant value analysis</i> . . . . .	88
3.2.12. <i>Discussion groups development</i> . . . . .	89
3.2.13. <i>Discussion groups results</i> . . . . .	90
3.3. <b>Validating the EVA protocol</b> <i>to the value-based innovation model.</i> . . . . .	91
Chapter 4. Starting a case of study . . . . .	93
a. <i>Introduction</i> . . . . .	94
b. <i>Problem, hypotheses and rationale of the study.</i> . . . . .	95
c. <i>Methodology</i> . . . . .	95
d. <i>Literature review.</i> . . . . .	97
e. <i>Analysis</i> . . . . .	98
f. <i>Results</i> . . . . .	102
g. <i>Conclusions and future studies</i> . . . . .	107
Conclusions . . . . .	110
References. . . . .	112
Acerca de los autores . . . . .	123

# Introduction

What is the main reason to formulate values in the firms or organizations? The main answer is to facilitate the alignment of employees and organizational values to increase motivation and effectiveness with better outcomes in performance and investment alike. However, there are few efforts to design, implement and prove empirical models to analyze their results that conform an integral view of factors involved in a value-based management model. The mentioned above, represents a great opportunity for the management sciences to show their abilities to propose a model able to determine and weight an inventory of values per industry/sector and select the values, according the division or department of the firm or corporate organization. Due to the values-based innovation is the main reason of this book and according as mentioned above, this is divided in:

*Chapter 1* highlights the importance of values for management sciences, showing, several values studies and models that describe them, and the main key performance indicators to assess them, inspired on values-based management. Remarkable models are explained, such as Evaluation VALUE protocol (**EVA protocol**), that is introduced as a tool of selecting values from a previous determined inventory.

*Chapter 2*, describes the relationship between values and innovation and the recent and novelty models as the value-based innovation management model (Breuer, H. and Lüdeke-Freund

(2015), and its relationship with the open innovation model (Mejía-Trejo, 2017 b)

*Chapter 3*, describes the general conceptual model proposal, based on the models mentioned above, and describing the process of **EVA protocol** to be applied. The model proposal includes a broad scope to define specific values into specific areas, interchangeable along horizontal or vertical structure of the firm or corporate organization, with certain characteristics such as: normative, strategic and/or instrumental/operational as management views. It is previewed, three innovation management associated with each one of the management views: the normative, the business model and the process-product-service innovation views. A decision point is incorporated in order to change or not the actual values on operation. If the answer is no, the process continues in its own flow of feedback linkage to keep the supervision of the key performance indicators such as efficiency or effectiveness inspired in values-based management as a feedback linkage; if the answer is yes, then the **EVA protocol** process is applied as a feedback linkage to review, modify, interchange, suppress or enter new values according to the division, the department within the firm or corporate organization.

*Chapter 4*, as a benchmarking research of the most innovators firms at worldwide, no matter what industries or sectors are being, shows an empirically study case as a preliminary stage to determine an inventory of values with innovation view, based on Mejía-Trejo (2017c) research applied at Guadalajara's Mexico software development firms with the hope to be implemented in Spain for future studies.

Finally, the conceptual model proposal is considered important and ready to be applied in any sector of the industry interested in the values-based innovation management, due its flexibility, simplicity and broad scope to measure the performance of the firm or corporate organization not only in the economic value, but in the general perception of value in all the involved parties.

# Chapter 1

## The importance of values in management sciences

Although values in management have deserved attention for several decades, value concepts have not been specifically worked out for organizational settings (Stackman *et al.*, 2000). Many personal aspects will interact to determine the actions of a person in its behavior. Attitudes, motivations, perceptions, skills, personality, knowledge, confidence, commitment and experience, amongst others, are a few of the variables which are important for understanding the behavior of people. They are no less important for understanding the behavior of people at work as a manager whether they are leaders or not in a small firm or corporate organization.

### ***1.1. Some studies of values in the management sciences***

The study of values is not new in the social sciences; according to Spranger (1928), an early and influential writer, values are defined as the *constellation of likes, dislikes, viewpoints, the duties, inner inclinations, rational and irrational judgments, prejudices, and association patterns that determine a person's view of the world*. The importance of a value system is that once internalized it becomes, consciously or subconsciously, a standard or criterion for guiding one's action. Thus the study of managers values is extremely important to the uncover the values managers actually have.

The most influential theory is based upon the thinking of Spranger (1928) who defined several types of value orientation as shown in Table 1, and has been developed by Guth and Tagiuri (1965). They studied the expressed values of 653 American executives, using a closed instrument, of rank order type, detecting that the executives in the sample in terms of group averages presented a *predominance of economic, political and practical values*. See **Table 1.1**.

*Table 1.1*  
Types of value orientation

Value orientation	Description
The economic man	It is primarily oriented toward what is useful. He is interested in the practical aspects of the business world; in the manufacture, marketing, distribution and consumption of goods; in the use of economic resources; and in the accumulation of tangible wealth (protestant ethics). He is thoroughly <i>practical</i> and fits well the stereotype of the businessman.
The theoretical man	It is primarily interested in the discovery of truth, in the systematic ordering of his knowledge. In pursuing this goal he typically takes a <i>cognitive</i> approach, looking for identities and differences, with relative disregard for the beauty or utility of objects, seeking only to observe and to reason. His interests are empirical, critical, and rational.
The political man	It is oriented toward power, not necessarily in politics, but in whatever area he works. Most leaders have a high power orientation. Competition play a large role during all his life. For some men, this value is uppermost, driving them to seek personal power, influence, and recognition in a continuous basis.
The aesthetic man	It finds his main interest in the artistic aspects of life, although he need not be a creative artist. He values form and harmony. He views experience in terms of grace, symmetry, or harmony. Lives the here and now with enthusiasm.
The social man	It is primarily oriented toward the well-being of the people. His essential value is love of people (the altruistic or philanthropic aspect of love). The social man values people as ends, and tends to be kind, sympathetic, and unselfish.

Source: Guth and Tagiuri (1965).

Additional support to these findings can be found in the studies of England (1967) involving a survey of 1,072 American managers. A follow-up study of England's results some seven years later found that managers' *values had not shifted* (Luck, 1974). The idea that managers as a group tend to emphasize the importance of economic, or practical, ends is intuitively appealing; after all, the theory and research of the managerial process suggests that persons with such values would be compatible with it. Another important facts hindering any change in the value system orientation are: **a)** managers are selected by others having similar values, **b)** the job of managing reinforces the pragmatic orientation, and **c)** values are in the axiomatic core of the individuals, *therefore they tend to be stable over time.*

Other model under consideration, is aimed as organizational issue by Strickland and Vaughan (2008). The starting point of the model is Maslow's hierarchy of needs and when translated to the organizational context, five sets of values in a sequential. See **Table 1.2.**

*Table 1.2*  
Organizational values base on Maslow hierarchy needs

Organizational values	Description
Financial competence	Wise asset management and maintaining solvency is a prerequisite for an organization to survive.
Accountability	Transparent procedures, proper oversight, and external control. These values help an organization to protect itself from unethical behavior and prevent the expenditure of resources to investigate or mitigate the consequences of such behavior.
Reciprocity	Maximizes acceptance and trust both inside and outside the organization and is achieved via a clear understanding of what the organization seeks to do, how and why.
Respect	Relationship development, tolerance of differences of opinion, cultural diversity, etc.
Integrity and self-actualization of the organization	Completeness and commitment to ethical behavior, stewardship, serving the public.

Source: Strickland and Vaughan (2008).

In the spirit of Maslow’s hierarchy of needs, this is the only concept where value sets are presented in hierarchical order. Of course, one has to be careful about the application of concepts developed for the individual level to other levels (Peterson, 2004). The order of the value sets in **Figure 1.1** rests on the values hierarchy suggested by Strickland and Vaughan (2008). The lower level value set deals with economic issues, the second level seeks counterparts for reciprocity and respect values, and the highest level contends with the fulfillment of organizational and individual goals. **Figure 1.2** shows the emerging similarities in four approaches described. Three studies (Abbott *et al.*, 2005; Dolan and Richley, 2006; Strickland and Vaughan, 2008) start with the value set that makes an organization sustainable – (survival values.). See **Figure 1.1**

*Figure 1.1*  
Organizational values dimensions

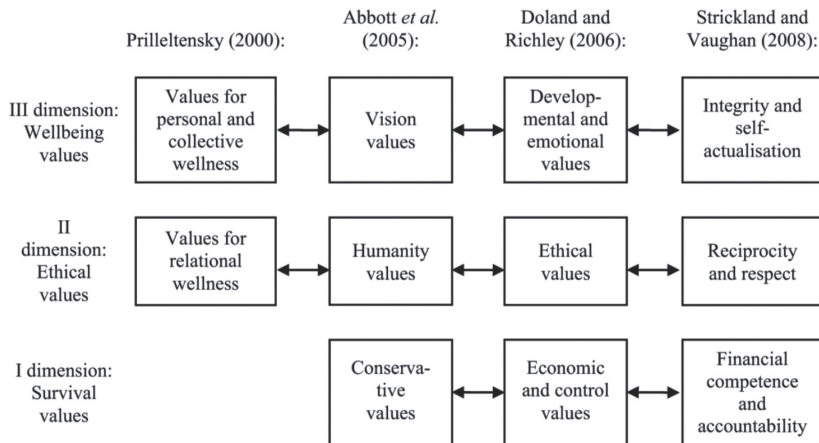

Source: Jaakson (2010).

*Survival values* need not be explicitly articulated for the public, but are, nevertheless, implicitly important. Values in the middle dimension deal with *ethics and behavioral norms* and there is

an agreement in all studies that the task of these values is to *enhance good relations inside and outside the organization*. The final dimension of values defines the ultimate purpose of the organization and *seeks an alignment of them with the goals of stakeholders relevant for the organization*. They are called *well-being values* in the current model. The argument is in favor of defining the core values, *those that reflect attitudes and character*. When put into the context of value dimensions, these relate to *ethical values* in the first place, because *ethical values regulate the means, whereas well-being values and survival values are more concerned about the ends*. It has been demonstrated that *ethical and well-being values drive positive workplace behaviors* (Abbott *et al.*, 2005). Therefore, ethical values seem to be the best candidates for the *values statement and well-being values should be stated in the manner of attitude or character*. Survival values, if included in the values statements at all, should also refer to desired attitudes rather than organizational objectives (Jaakson, 2010).

Other study inspired in Maslow needs is the *elements value* (Almquist *et al.*, 2016) based on the view of when customers evaluate a product or service, they hits perceived value against the asking price. Marketers have generally focused much of their time and energy on managing the price side of that equation, since raising prices can immediately boost profits. But that's the easy part: Pricing usually consists of managing a relatively small set of numbers, and pricing analytics and tactics are highly evolved. What consumers truly value, however, can be difficult to pin down and psychologically complicated. How can leadership teams actively manage value or devise ways to deliver more of it, whether functional (saving time, reducing cost) or emotional (reducing anxiety, providing entertainment)? Discrete choice analysis, (which simulates demand for different combinations of product features, pricing, and other components) and similar research techniques are powerful and useful tools, but they are designed to test consumer reactions to preconceived concepts of value, the concepts that managers are accustomed to judging.



Coming up with new concepts requires anticipating what else people might consider valuable. Yet universal building blocks of value do exist, creating opportunities for companies to improve their performance in current markets or break into new ones. A rigorous model of consumer value allows a company to come up with new combinations of value that its products and services could deliver. The right combinations, its analysis shows, pay off in stronger customer loyalty, greater consumer willingness to try a particular brand, and sustained revenue growth. Almquist (*et al.*, 2016) identified 30 *elements of value* or fundamental attributes in their most essential and discrete forms (see the exhibit *The Elements of Value Pyramid*). These elements fall into four categories: *functional, emotional, life changing, and social impact*. See **Figure 1.2**

The use of Maslow's thinking in the model considering, at the bottom of the pyramid the physiological and safety needs, and at the top are self-actualization and self-transcendence. The popular assumption has been that people cannot attain the needs at the top until they have met the ones below. Maslow himself took a more nuanced view, realizing that numerous patterns of fulfillment can exist. Similarly, the elements of value pyramid is a heuristic model (practical rather than theoretically perfect) in which the most powerful forms of value live at the top. To be able to deliver on those higher-order elements, a company must provide at least some of the functional elements required by a particular product category. But many combinations of elements exist in successful products and services today. Most of these elements have been around for centuries and probably longer, although their manifestations have changed over time. The relevance of elements varies according to industry, culture, and demographics.

The elements of value work best when a company's leaders recognize them as a growth opportunity and make value a priority. It should be at least as important as cost management, pric-

Figure 1.2  
Value Pyramid

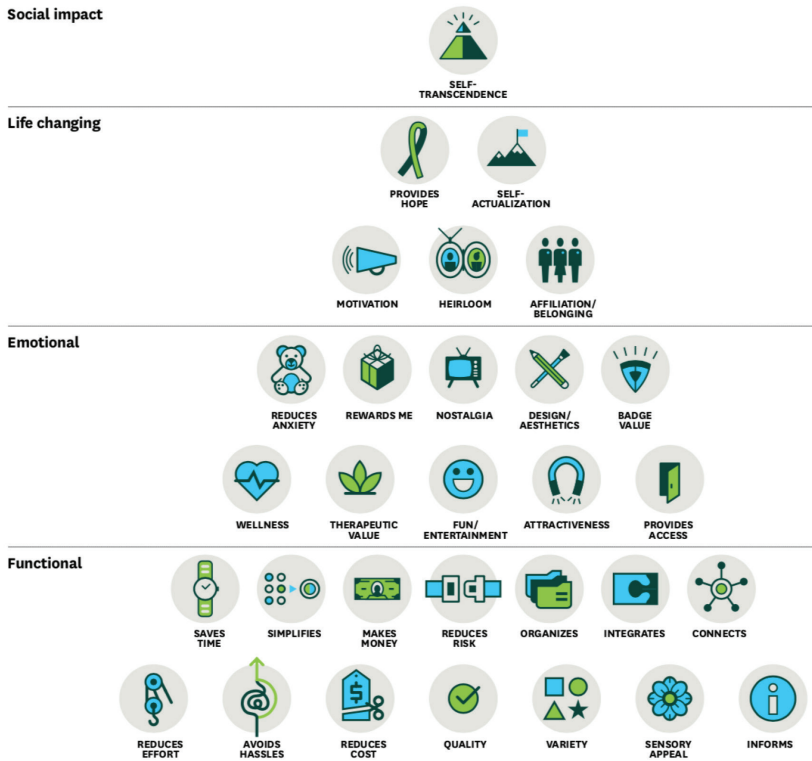

Source: Almquist (*et al.*, 2016).

ing, and customer loyalty. Companies can establish a discipline around improving value in some key areas:

**New-product development.** Our model can stimulate ideas for new products and for elements to add to existing products. Managers might ask, for example: Can we connect in a new way with consumers? Can our customers benefit from integration with other software applications? Can we add therapeutic value to our service?

**Pricing.** Managers commonly view pricing as one of the most important levers in demand management, because when demand is constant, higher prices accrue directly to profits. But higher prices also change the consumer value equation, so any discussion about raising prices should consider the addition of value elements. Recall how Amazon's judicious increases in value helped justify higher prices over time.

**Customer segmentation.** Most companies have a formal method of segmenting their customers into demographic or behavioral groups, which presents an opportunity to analyze what each of these groups values and then develop products and services that deliver those elements.

The concept of value remains rooted in psychology, but the elements of value can make it much less amorphous and mysterious. Abraham Maslow emphasized the bold, confident, positive potential of psychology. The elements can help managers creatively add value to their brands, products, and services and thereby gain an edge with consumers, the true arbiters of value. See **Table 1.3**.

## ***1.2. Importance of the values***

Values will affect not only the perceptions of appropriate ends, but also the perceptions of the appropriate means to those ends. From the concept and development of organization strategies, structures and processes, to the use of particular management styles and the evaluation of subordinate performance, *value systems will be persuasive*. Fiedler (1967) came up with a leadership theory based upon the argument that *managers cannot be expected to adopt a particular leadership style if it is contrary to their value orientations*. An influential theory of leadership (Covey, 1990) is based upon four dimensions: *personal, interpersonal, managerial, and organizational*. *Not by accident the personal dimension is considered the core dimension*. Incidentally it encom-

Table 1.3  
Different values for different products

What customers value in products varies by industry. Here are the top five elements influencing loyalty for 10 types of businesses.

<p><b>APPAREL RETAIL</b> QUALITY VARIETY AVOIDS HASSLES DESIGN/AESTHETICS SAVES TIME</p>	<p><b>TV SERVICE PROVIDERS</b> QUALITY VARIETY REDUCES COST DESIGN/AESTHETICS FUN/ENTERTAINMENT</p>
<p><b>DISCOUNT RETAIL</b> QUALITY VARIETY REDUCES COST SAVES TIME REWARDS ME</p>	<p><b>CONSUMER BANKING</b> QUALITY PROVIDES ACCESS HEIRLOOM AVOIDS HASSLES REDUCES ANXIETY</p>
<p><b>GROCERY</b> QUALITY VARIETY SENSORY APPEAL REDUCES COST REWARDS ME</p>	<p><b>BROKERAGE</b> QUALITY MAKES MONEY HEIRLOOM VARIETY PROVIDES ACCESS</p>
<p><b>FOOD AND BEVERAGES</b> QUALITY SENSORY APPEAL VARIETY DESIGN/AESTHETICS THERAPEUTIC VALUE</p>	<p><b>AUTO INSURANCE</b> QUALITY REDUCES ANXIETY REDUCES COST PROVIDES ACCESS VARIETY</p>
<p><b>SMARTPHONES</b> QUALITY REDUCES EFFORT VARIETY ORGANIZES CONNECTS</p>	<p><b>CREDIT CARDS</b> QUALITY REWARDS ME HEIRLOOM AVOIDS HASSLES PROVIDES ACCESS</p>

Source: Almquist (*et al.*, 2016).

passes the value profile of the individual. Tannenbaum and Schmidt (1958) suggested that there are at least four internal forces that influence a manager's leadership style: *value system, confidence in employees, personal inclinations, and feelings of security in an uncertain situation*. Again value system plays an impor-

tant role. In short, people decide according to the value system they spouse, in other words values and attitudes are important because they may shape behavior, and behavior will influence people (Bruno, 2010).

### ***1.3. Managers and values***

Employees will be the essential resources of twenty-first century organizations. These employees can be categorized into several generations, each with special motivation needs. Managers and leaders need to understand people, whatever their age. They need to find out their skills, strengths, and whatever motivates them. In short they have to recognize that everyone is different and deal with each employee as an individual (Bruno, 2010).

On the other hand, there are some important considerations that the manager of tomorrow will be confronted with: **a)** the phenomenon of unemployment, as a consequence of the extraordinary fast development of mechanization and automation, and the economic apparatus centered in the idea of currency stability, which instead of absorbing all the units of human energy creates a growing number of idle hands, and, even worse, brains; **b)** the phenomenon of research( who can say whither our combined knowledge of the atom, of hormones, of the cell and the laws of heredity will take us?); and **c)** the need for true union, that is to say full associations of human beings organically ordered, which will lead us to differentiation in terms of society; it should not be confounded with agglomeration which tends to stifle and neutralize the elements which compose it. Therefore, responsible influence, leadership centered in collective objectives, coherence and fecundity, are the four criteria to be pursued in developing the leaders of tomorrow. Organization's managers need to set directions and create a customer focus, clear and visible values, and high expectations, which should balance the needs of all stakeholders; ensuring the creation of strategies,

systems, and methods for achieving excellence, innovation, and building knowledge and capabilities, including the development of leadership (Nanus, 1995)

#### **1.4. The Values-based management**

Value-Based Management is a company's management approach to value creation, particularly by maximizing shareholder value (Robu and Ciora, 2008). In the context of competitiveness and increasing demands on performance, value creation should be subordinated to sustainable development as a bridge to the community, customers and employees. Value-Based Management includes: **a. *Creating Value*** (ways to maximize growth and future value). This includes defining strategies for companies both short and long term. **b. *Managing by value*** (governance, change management, organizational culture, communication, leadership). **c. *Measuring value*** (assessment). These elements are very well outlined steps in the company's objectives and especially in the management of the company. Management's planned strategies can have a major impact on future actions of stakeholders, so that management should take into account their interests in parallel with the interests of stakeholders. Items included in the value-based management. See **Figure 1.3**.

Economic objectives can be either economic (*shareholders value*) and may also cover the other parts (*stakeholders value*). The vision of the shareholders' value over the value of stakeholders' value is discussed in the economic environment for a long time, concentrating to find the best options that a company should be centered to both perspectives. In market economies, there is an agreed idea that a company must follow economic profitability. Moreover, companies must search for a high level of social responsibility for their future development. Most times, profitability and responsibility are contradictory, resulting in management decisions directed toward one of the two concepts.

Figure 1.3  
Value-based management factors



Source: Robu and Ciora (2008).

On the one hand, companies must be profitable to survive and big companies need to remunerate capital at a rate of return that exceeds its cost (Jaakson,2010) This rate of return should be higher than the interest obtained in the case of a bank deposit in order for business development to be justified. Improving profitability, and consequently a higher income leads to increasing investor confidence, reflected by increasing the stock's price, which makes it easier to achieve long-term business goals. *Such profits are not just results, but a source for future competitiveness and prosperity* (Robu and Ciora ,2008). See **Figure 1.4**.

On the other hand, companies are organizations where people work together. By developing technologies and services, employees represent now most of the company's value (*intellectual capital*). To motivate employees to work more closely to company interests, a level of trust must be built with them. Same level of trust needs to be developed with the external environment with which the company interacts. Thus the company get daily

Figure 1.4  
The relationship between the company,  
shareholders and stakeholders

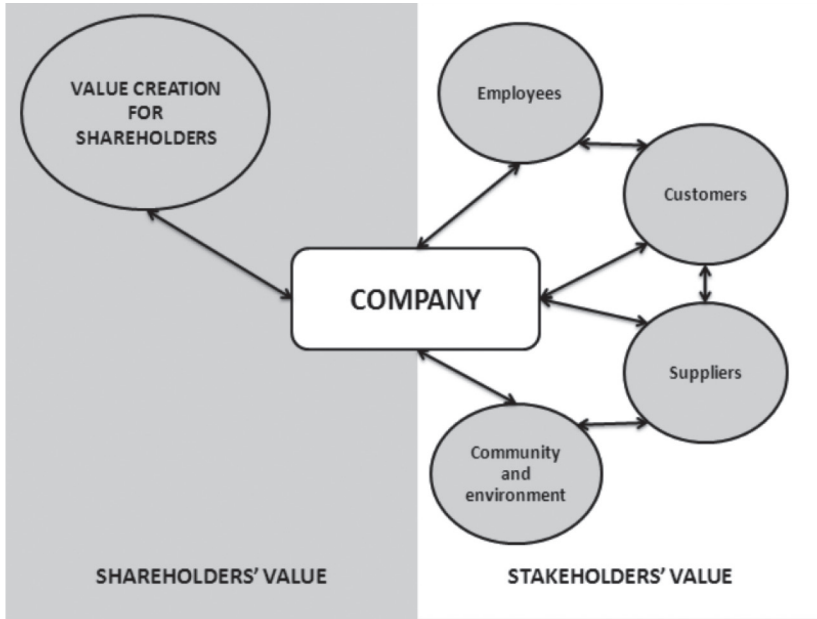

Source: Robu and Ciora (2008).

in contact customer, for whom it must design loyalty programs to keep old customers, and promotions to attract new clients. A direct relationship and based on the confidence of suppliers is a strength in business development. Starting from timely receipt of orders and payment methods, relationship with suppliers can make a difference in a competitive economy, influenced by globalization. Finally, the company must follow closely the relationship with other categories of stakeholders (government, community and environment), so direct connection between the company and related parties will lead to increasing profitability (Robu and Ciora, 2008; Jaakson,2010).

All the concepts mentioned above, in a technical sense, can be difficult to express in terms of *productivity, efficiency and*



*effectiveness* as indicators of values-based management (Jaakson,2010), but they are important for comprehending the possibilities of these measurement indicators, but we define them as follows:

#### 1.4.1. Productivity

According to Longman (2017) is: *The rate of which goods are produced, and the amount produced, compared with the work, time, and money needed to produce them.* It is often applied as an indicator of innovation and development in an industry and is frequently used in comparative analyses. It is generally described as a fraction of production outcome over input. Basically, it describes the value of goods or services of a production over a period of time in proportion to the contribution of production factors. According to the **KLEMS** model (OECD, 2001) the production factors are: *Capital (K), labor (L), energy (E), materials (M) and services (S) as elements of multifactor productivity (MFP)* based on a value-added concept of output, or in the form of **MFP (KLEMS)**, a concept of gross output. Productivity is difficult to measure because outputs and inputs are quite diverse and are hard to measure. The choice between the different productivity measurements depends on the purpose and, in many instances, on the availability of data. Productivity only stresses the importance of producing with a minimum of resources and the capabilities of adding *value* to the product, whereby the price is as high as possible. *The main lack, however, is that productivity does not take into consideration whether it is the right product we produce, and furthermore, no indications of who the buyer is . That is why productivity is inadequate to measure the full potential of values-based view, and, therefore, why we should use efficiency and effectiveness as indicators of innovation and development.*(Wandahl, 2004).

### 1.4.2. Effectiveness and efficiency

According to Longman (2017) the effectiveness: is producing the result that was wanted or intended, and Efficiency: is quality of doing something well, without wasting time, money, or energy. A model of interested parties is used to explain the difference between efficiency and effectiveness. See **Figure 1.5**.

Figure 1.5

Interested parties model to explain efficiency and effectiveness

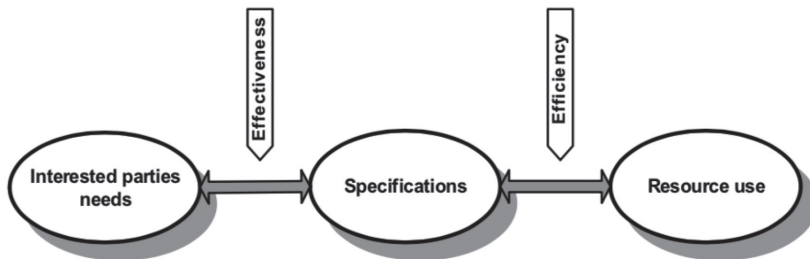

Source: Bruzelius and Skärvad (1989).

Attention is drawn to the fact that the model not only addresses the construction client's needs, but all the interested parties' needs. The interested parties' needs should be perceived widely. The **Figure 1.2** shows the importance of comprehending the difference between efficiency and effectiveness. Effectiveness is an expression of the level of correspondence of the specifications with the interested parties' needs. Efficiency has two dimensions. Firstly, the achieved specifications are compared with the needed specifications, and secondly, the production of these specifications compared with the level of used resources. To put the efficiency / effectiveness differentiation into perspective, a model using a product / process viewpoint can be helpful. This is shown in **Figure 1.6**.

*Figure 1.6*  
Efficiency and effectiveness through  
a product/process viewpoint

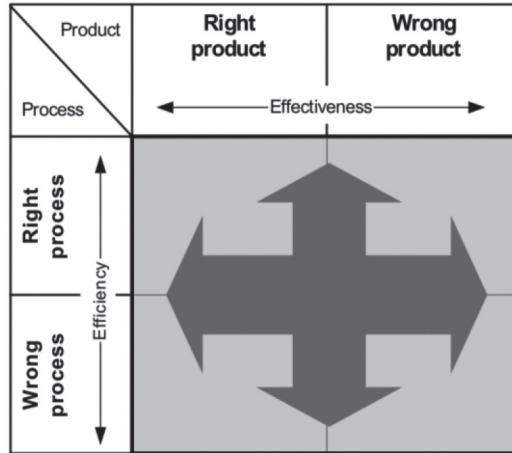

Source: Wandahl (2002).

Vertical movements can be perceived as change in efficiency, and horizontal movements could be characterized as effectiveness. A right answer should then be to produce the right product in the right manner, for instance, placed in top-left corner of the figure. At last in this exploration of the concepts, you may ask *what the difference between efficiency and productivity is*. In productivity the numerator is the gross output, described in money. Efficiency has instead, the specifications of the construction client and also of the other parties as numerator, this gives a more nuanced picture of the production. It is possible to achieve high productivity at the expense of efficiency by obviously avoiding fulfilling the specifications or making errors. The central element in both measurements is, therefore, the use of resources.

Efficiency and effectiveness were defined through three areas, customer needs, product specifications, and use of resources (See **Figure 1.2**). Several theoretical connections between Value-based management an increase in efficiency and effective-

ness are discovered, and they are best explained through some simple models. Efficiency and effectiveness should be applied as key indicators of innovation and development because they contain the holistic ideas of modern project management concepts. The contents of these concepts should be elements like holistic product development, fast adaptable structures and focus on human capabilities.

### ***1.5. Values vs. Value-based management***

To understand value-based management it is important to be aware of the complexity and the differentiation of the value concept. Value has always been used in one manner or another, but never consistently due to the lack of a common definition of the concept. *Be aware that price and value are not identical.* Value is connected to the product and the process, price is only an expression for how much the market is willing to pay for the value delivered (Wandahl,2004). In everyday life, the term value is often connected with human behavior. Human behavior is more or less consciously influenced by the individual's values. This kind of value is called ethical/personal value and is very subjective. Ethical value could be explained as an individual for what you find good/bad and right/wrong. Covey (1989) explains it very nicely as the paradigm through which you see the world through human behavior as a main part of the process (transforming a product from one state to another), and this kind of value is, therefore, called *process value*. We now have two groups of value. See **Figure 1.7**.

Figure 1.7

The two sets of values used in value-Based Management

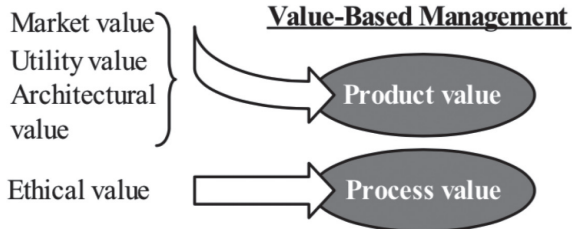

Source: Wandahl and Bejder (2003).

The two groups of value have some common characteristics (Wandahl, 2004):

- *Value is subjective* and, therefore, personal. Attributes of value can be objective, but the perception of these is always subjective.
- *Value is essentially comparative*. Goods do not have any value on their own, only in comparison with others; that is they are relative.
- *Value can change over time*, and they, thereby, have a time dependent and dynamic element.
- *Value is certain forms of characteristics, not substantive quantities*. To create value is to create products and processes with certain characteristics.

There are several areas that influence human behavior, for example: Values, goals, market framework, systems and structures. A model for this is shown in **Figure 1.8**.

Two kinds of value management can be extracted: management of values primarily uses product values and seeks maximization of the value delivered to the construction client by influencing human behavior via systems and structures. One of them is known as *management of values* as seen in for instance, in lean construction. When it talks about values, it is in connection with removing waste (non-value-adding activities) and

Figure 1.8  
Behavior regulation in value-based management

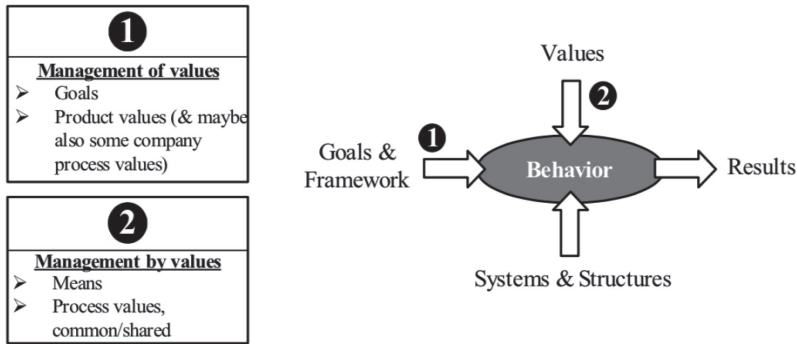

Source: Wandahl and Bejder (2003).

increasing the product value for the customer. The other one is *management by values*, commonly agreed (shared) values uses process values as a supplementary tool to manage human behavior. This is what some prefer to call management by *soft* areas. Value-based management is a combination of them, but with the primary focus on the use of process values as means for creating higher product values (goals)(Wandhal. 2004). Management by values is defined in as a *series of interconnected managerial activities to ensure the acceptance of relevant organizational values inside and outside the organization* (Jaakson, 2010).

There are several elements which contribute to the positive effect that focusing and working with process values (*soft values*). A project organization has a short lifetime, and the way the organization is established (tendering on lowest price) makes it difficult for the participants to relate to each other on an interpersonal level. In addition, the organization must almost immediately show results. It is, therefore, important to quickly establish a common basis for making decisions. In our rational world this is presently done by rules, laws, contracts, etc. The problem in this respect, is that an outcome of a human action reflects the way you measure it. When the constructing managers success

and his future connection to his firm are measured by how much money he can save/earn on short time basis, he will naturally act accordingly, and this is exactly the earlier described sub-optimization. Instead of using laws, contracts, etc. as the common background for making decisions, Values-based management uses social rules, for instance, behavior regulations on a group level. The real barrier is then to get the firms involved to accept this change, and furthermore. Many of the companies have difficulties earning profit. They, therefore, focus a lot on liquidity, which again creates a short-term focus on only the present project. Development and innovation have, therefore, very hard conditions (Wandahl, 2004).

### **1.6. Management by values**

Organizational values, in technical terms, are qualities and standards that have a certain weighted which decision-makers in the organization attach to alternative goals when making a decision (Van der Wal and Huberts, 2007). According Roe and Ester (1999), organizational values is defined as: *...latent constructs that refer to the way in which people evaluate activities or outcomes...* This definition is chosen because it pinpoints the uniting features of several definitions of values; in addition, they explicitly mention that the definition is applicable at various levels (individual, group, such as organization, or nation). The definition also distinguishes *means (activities) and ends (outcomes)*, an important characteristic for management of values.

The first important note to make about organizational values in the context of MBV is its *latency*. *Management by values* makes use of values that are clearly spelled out and aimed to be accepted by relevant organizational stakeholders, so these have to be explicit. Here, it is common for organizations to come up with a *values statement*, as specific set of publicly stated organizational beliefs or concepts (Buchko, 2007). *When values are es-*

*poused they are typically stated in writing for all members of the organization, and are shared with other stakeholders, including the general public. It should be mentioned, though, that the values statement is only the tip of the iceberg when it comes to organizational values in operation (Jaakson, 2010). Specifically, the statements cover only those aspects that managers find useful to publish as an ideology or a focus for the organization (Schein, 2004). It is highly problematic when values manifested in the statement are in conflict with actual values or basic underlying assumptions, but one should be aware that the pool of organizational values is probably much wider and complex than reflected by the statement (Jaakson, 2010).*

There is quite an amount of confusion in the terminology about organizational values. The values in the values statement are called *espoused values*, *principles or stated values* (Argyris and Schön, 1978; Schein, 2004; Mowles, 2008), sometimes also *core values* (Edgeman and Scherer, 1999; Van der Wal and Huberts, 2007). The uniting feature of those terms is that at least the members of the organization are well aware of them. In contrast to *espoused* and *stated values*, *core values need not be explicitly stated in written documents*, although they typically are a result of a dispute that has taken place in the organization about the relevant values. *Core values* have also been used to denote highly congruent values between organizational members as well as between the organization and its members (Jehn, 1994) and as such, these refer to at least some overlap between what is actually believed in and what is said to be believed in (Jaakson, 2010). This need not be the case with *espoused values* or *stated values*. Consequently, the extent of acceptance of the values may be higher in the case of *core values*. See **Figure 1.9**.



Figure 1.9  
Terms used to designate organizational values  
and values statements

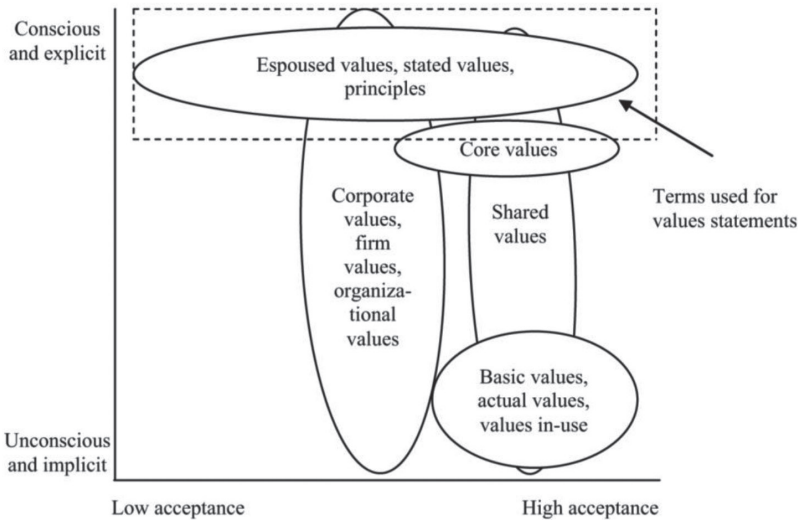

Source: Jaakson (2010).

Very often, the term *shared values* is used in organizational culture and management by values literature (Peters and Waterman, 1982; Griseri, 1998; Schein, 2004). In contrast to *espoused values*, *shared values* do not have to be explicitly stated, and in contrast to *core values* they might be unconscious. *Unconsciousness* yet high acceptance is a defining feature of the terms *basic assumptions*, *basic values*, *actual values* or *values in use* (Argyris and Schön, 1978; Schein, 2004). These values are associated with organizational culture. But there is still more said about the terms for organizational values and there is no systematic approach, whether authors talk about *conscious explicit values* or *unconscious implicit values*. For instance, *corporate values* (Rubino, 1998; Thomsen, 2004), *firm values* (Pant and Lachman, 1998) or *organizational values* (Finegan, 2000; Speculand and Chaudhary, 2008) may represent values on both ends depend-

ing on the particular author. The question of acceptance is usually not discussed at all with these terms. **Figure 1.5** presents a systematic framework to illustrate the differences in the terms used in the literature on organizational values and points out the main differences with respect to management by values. It is assumed that the values should be at least brought to the *conscious level, preferably be explicit*. However, the aim is that they reflect the values that are shared by the members of the organization and are actually in use, so *espoused values* on the right hand side of the **Figure 1.6** or *core values* is in focus.

### ***1.7. The organizations and categories of values***

here is no organization without values (Schein, 2004), so they are always present and manifest themselves in organizational artifacts, behaviors, processes, structures etc. Thus, values have an expressive role, but when it comes to management by values, the role of values is first and foremost to regulate employee behavior to achieve superior performance. That means that the effectiveness of management by values partly depends on the effectiveness of the defined values in the values statements and in order to assess the effectiveness of these it is useful to analyze different value categories. The following sections aim to clarify the characteristics of the values that are deployed in management by values. According to the definition, values regulate both means and ends. Some values are related to desired outcomes, whereas others are instrumental in making it possible to reach those end-states. A categorization, reflecting these functions in the organization, has been adopted by Dolan *et al.* (2003). They talk about basic or final values (where the organization is heading and why it exists) and operating or instrumental values (what are the organization's ways of thinking and ways of doing in order to achieve basic values). Basic values are similar to *ideals* as suggested by Maccoby (1998) and referred to as *aspira-*

*tional values* by Lencioni (2002). Similarly, the *created values* put forward by Wenstop and Myrmel (2006) resemble these values because they envisage tangible outcomes that different stakeholders expect from an organization. Thus, there are different terms used by different authors to express the values that regulate the objectives of the organization. See **Table 1.4**.

*Table 1.4*  
Organizational values regulating means and ends

Value as a:	Authors			
	Dolan <i>et al.</i> (2003)	Maccoby (1998), Griseri (1998)	Lencioni (2002)	Wenstøp and Myrmel (2006)
<b>Ends</b>	Basic values, final values	Values as ideals	Aspirational values	Created values
<b>Means</b>	Operating values, instrumental values	Values as behavior Values as character	Permission-to-play values Core values Accidental values	Protected values Core values

Source: Jaakson (2010) with own adaptation.

*Operating or instrumental values* are more complex. They could be approached both, from a behavioral point of view or *what one should/should not do* and from an attitude or character point of view or *what one should be like* (Griseri, 1998; Maccoby, 1998). For instance, a behavioral outcome of the value teamwork would be that the work in the organization is *organized in teams rather than by individual assignments*. A character outcome of the same value implies that employees share a strong belief in group synergy. It is assumed that attitude at least partly determines behavior, but the question is rather which one takes priority. Behavioral values often boil down to normative rules and standards; such values are referred to as *permission-to-play values* by Lencioni (2002) and *protected values* by Wenstøp and Myrmel (2006). *The characteristics of these values are the absence of emo-*

tions and their inability to distinguish an organization from its competitors. By contrast, values as character reflect emotions and attitudes; they form the heart of an organization's culture. Character is expressed via core values (Lencioni, 2002, Wenstøp and Myrmel, 2006). This function as a backdrop to all activities in the organization and are a source of the company's distinctiveness. In addition, Lencioni (2002) talks about *accidental values*, which reflect employee interests (thus being an element of character), but have little to do with the organization's actual aim, strategy and basis for success. **Table 1.2** shows that authors label values with similar spheres of regulation dissimilarly, but the underlying categories are still the same.

*The categories of values are relevant to distinguish because in trying to manage by values one should understand what types of values are more efficient for managerial purposes.* It has been suggested that values statements should be about how rather than what to do (Dolan and Richley, 2006). This is to say, that while values regulate both *ends, and means*, it is the latter realm, which deserves closer-scrutiny. The same idea is embedded even in some definitions of organizational values, for example: *values are here-and-now beliefs about how things in the organization should be accomplished* (Kouzes and Posner, 1991, p. 191).

Instrumental values guide the process of working toward a desired state of affairs by regulating daily conduct of individual employees, yet they also have a merit of their own (Prilleltensky, 2000). Basic values are no less relevant, but ideals and aspirations have their place in the organizational vision and mission rather than values statements (Lencioni, 2002; Dolan and Richley, 2006). Burns (1978) established that transformational managers use *transcendent* (for instance, basic) values rather than *modal* (for instance, instrumental and operational) *values to inspire people*.

### **1.8. How to weight and determine a value?**

Values affect the perception of the concept and development of organization structures, strategies, and processes, even the practice of certain leadership style and the evaluation of subordinate performance where managers cannot be expected to adopt a particular leadership style if it is contrary to their value orientations (Bruno, 2010). After all, since the early 1960s management theorists have discussed the origins of corporate culture, observing how organizations develop a personality based on shared beliefs and that these are shaped by the founder or leader. Again, value system plays an important role. In short, people decide according to the value system they spouse, in other words values and attitudes are important because they may shape behavior, and behavior will influence people through the management practice. (Bruno, 2010), and they must be measured.

According Rodríguez-Bravo (*et al.*, 2013): *...the concept of value is extremely polysemic and therefore ambiguous. It is used in very different fields with different nuances: human value, energy value, biological value, adaptive value, planable value, declared value, value added, exchange value, average value, nominal value, etc. In addition, the concept of value is handled in a very daily and habitual way, giving it a generic meaning of quality or positive quality...* Hence, to be more accurate, in this study we follow the definition of values-based innovation of Breuer, H. & Lüdeke-Freund, (2015) as: *principles involving attitudes of the organization and beliefs about innovation, enforcing an approach of the organization towards the innovation process and express what the organization perceives towards innovation; some organizations choose to formalise these values in written form or are embodied in their culture.* It exists a special interest for fostering a culture of innovation in how it fits with their broader corporate values, for instance, when such values are clear about the level of permission that staff have to be innovative. The values-based innovation may refer to the philosophy, underlying beliefs, specific processes

relating to innovation in the organization or even specific expected attitudes and/or behaviours. For their meaningful and integration with the operations and culture of the organization, they will need to be supported by the expectations about performance and behaviour, and reinforced by processes based on the leadership of the firm. In fact, values-based innovation vary amongst organizations, due: the different relationships and priorities with clients and stakeholders, different points of view, traditions and contexts that will affect the organization's aims and innovation methodology. (Jaakson, 2010; Breuer, H. and Lüdeke-Freund, 2015).

### *1.8.1. Evaluation of values protocol (EVA)*

**EVA protocol** was designed by **LAICOM** (Laboratory of Instrumental Analysis of the Communication; Autonomus University of Barcelona, Spain) (Rodríguez-Bravo, *et al.*, 2013). It is aimed to measure the load of values transmitted in any communication (text, video, poster, radio program, TV program, etc.). The measurement is carried out by applying tests to non-expert subjects, after being exposed to the messages to be evaluated.

**EVA protocol** consists, firstable, in the creation of a list of appropriate values to be applied in a given social, business environment or professional sector (such as; banking, tourism or food company, or an education organization, etc.). All these sectors share some common values in a transversal sense. However, each professional environment also needs to develop a list of very specific values. The creation of lists of values is developed by applying the methodology of content analysis to different samples of documents having to be shared and accepted in a generalized way by the whole professional sector under study. The follow step, is the design of a tool, that allow us to weight and identify the load of each one of the selected values. This tool is tested and validated by applying it into a group of specialists in audiovisual communication and corporate communication.

These experts are aimed to check, if the tool is able to measure their perception of values in a proper way.

### 1.8.2. EVA protocol. How to weight a value

The **EVA protocol** uses semantic differential indicators (Osgood, Suci and Tannenbaum, 1957) with some adaptations due to the nature of pairs of opposite values, for adjectives or content substantives (such as: high-low, war-peace): however, this approach often becomes very difficult with the terms that express values (for example: what would be the antonyms of values such as family or identity? To solve this problem, the following axiom was postulated:

*The content of any communicated message (value) is always favorable, unfavorable or indifferent to a set of predefined values...*

This allowed to preserve in strictly positive way, the character of the values and it structures the test, to aim the subject evaluators to judge the extent of any communicate of specific value (for example the value *friendship*), on an ordinal scale of 7 degrees. This scale is presented in the test in the following way. (See **Table 1.5**)

*Table 1.5*  
**EVA protocol:** Weighting of a value

Unfavorable	Friendship						Favorable
	-3	-2	-1	0	1	2	

Source: Rodríguez-Bravo (*et al.*, 2013).

Thereby, the subjects that assess the values can indicate with a cross, their opinions in what degree a value is favorable and stimulating, or it goes against their beliefs analyzed. Other difficulty solved with **EVA protocol**, was the coding and the management of the data that these tables produce, especially the degree of reliability they have, the characteristics of the degree of coherence

or dispersion of the responses to each of the values. The solution was to weight the values obtained according to the coherence of the answers. Thus, **EVA protocol** reinforce with greater numerical power the data coming from answers with greater subjective coherence subtracting power from the values that received responses with more dispersion.

This weighting was done using the mode as a reference statistic and the parameters to calculate the global value load, according to the **Table 1.6**.

*Table 1.6*  
**EVA protocol parameters**

Parameters	Description
Intensity of Value	Figure that a subject assigns to each value. The range of the Intensity can be: -3, -2, -1, 0, 1, 2, 3 (see previous tables).
Mode statistic	Intensity that appears more frequently in the distribution of data of the respective values. The use of mode statistic is to adapt the scale to ordinal values. It defines the intensity of value by selecting one of the values into the range.
Coherence	Number of subjects that asses the same value in the same message, resulting an intensity of value coinciding with the mode statistic. <i>A greater number of subjects, coinciding with the mode statistic the answer coherence with respect to that value shall be high and viceversa.</i>
Reliability	<i>Coherence/ Total Number of Subjects</i> It may be at most = 1; this only occurs only when all the test subjects matching with the same intensity of value in a specific value. <i>A smaller number of subjects coinciding in the answer, the reliability results in a proportionally smaller number and further away from the unit.. Reliability&lt;=1</i>
Power of value	<i>Mode statistic * Reliability</i> It is a factor that weights the analyzed value in terms of the intersubjective coherence between the answers, so <i>whether more increasing the dispersion between the responses of the subjects under assessment, lower the reliability and, consequently, power of the value goes down too.</i>
Global load of value	$\Sigma \text{Power of value} / \text{Number of Power of value}$ It is expressed as a single real number between -3 and 3 (the values within the range defined by the semantic differential); this means, in other words how unfavorable or favorable is the value analyzed at respect to the values inventoried. That is, it provides a continuous variable that allows to measure the complex load of values able to accept the subject under study and compare it with the load of another.

Source: Rodríguez-Bravo (*et al.*, 2013).



## Chapter 2

# The relationship between values and innovation

Innovation produces a new kind of value; it is a product of a dynamic process. Value is created within relationships between people, objects, and practices, and it can be defined in many ways. In other words, *value depends on what is valued*. We may speak of economic, social, ethical, moral, ecological, or political value. However, this multitude of aspects or types of value should not discourage us from thinking systematically about value creation and key dimensions to which this array can be reduced. Innovation activities always require certain supporting mechanisms that make realization of the various dimensions of value possible and render their relationships visible and able to be assessed (Ruckenstein *et al.*, 2011). For innovation practices, commitment only to assess the economic value of new insights and ideas, often referred to in day-to-day discussions as added value, may even be harmful to the enterprise in question. *Value is created not by objects, or people but by activities aimed at promoting the creation of meaningful relations* (Graeber, 2001)

### **2.1. Values type in innovation management**

Nowadays, the innovation managers are concerned with a big issue: *the development and marketing of new human-centred products and services and the creation of competitive advantages based on strategic differentiation of their business models and offerings.*

However, neither suffices to cater to the personal or corporate values underpinning attitudes and behaviours, such as an orientation towards sustainability or privacy; values that are both motivating and restricting managerial decisions while also reaching beyond single organizations (Breuer y Lüdeke-Freund, 2015). Our proposal is a complementing based on the grasp of values as *subjective notions of the desirable* (Schwartz, 2012) as fundamental criteria for individual and organizational decisions and evaluations (Agle and Caldwell, 1999). Values must be understanding as what is being considered important, worth engaging, working or even fighting for by individuals or complex social actors such as corporations. If values are codified and reinforced (through management measures), they turn into obligatory *normative orientations*. Corporate vision, mission and values statements are typical examples.

All the firms and companies are required to make profits and for that reason they work economically. However, this is never all they do , because each part of the firms since the all entire organization until the individual employee, pursues a variety of *values*. There are several values in type and scope and may take the form of either, *means* (for instance, for an electronic manufacturer where cost reduction, healths, security values are critical) *or ends* (for instance, the time of delivery in service organizations). Some values are seemingly *explicit* (for instance, several brand values to communicate and differentiate the identity), and others could be *implicit* (for instance, the design as a brand value, but as a means of communication and strategy it is seemingly rare that has a deep impact on innovation) in the firm practices and their outcomes. Furthermore, some companies strive to reach very ambitious concepts such as justice, sustainability, process efficiency and risk reduction, or self-enhancement, auto-learning, new lifestyles based on fun, free-time or new forms to reach the healthiness against the poverty or diseases. It is possible to say that all the companies that are focusing their efforts to cultivate their values tend to be the

ones most successful in economic terms, and leading in terms of innovation (Breuer and Lüdeke-Freund, 2015).

The *normative orientations*, the *implicit and explicit values* implied in the firms or corporate organizations and their environment should be used to drive innovation. To do it, is necessary to consider different values across all the levels of the organization. When such values are obligatory, codified, communicated, and reinforced through management measures, referring to them as *normative statements and orientations*. Corporate vision, mission, and purpose statements are typical examples. Companies like Intel, Coca-Cola or Toyota showcase how a participatory review and a redefinition of corporate values may boost and direct innovation.

## **2.2. Innovation Management**

Today, exist several kind of values created and applied into the firms and corporate organizations, *but often they do not inform or direct innovation in their core businesses*, oftentimes missing direction in the generation, selection, and specification or the searching of new dare ideas. Hence, we have for one hand the practitioners disregarding values and normative orientations as a source and lever to drive innovation, and by other hand the innovation management literature, that has neglected the normative management dimension. According to Breuer and Lüdeke-Freund (2015) there are *three areas in which the integration of values and normative orientations into innovation management* leads to theoretically and practically relevant advancements. See **Table 2.1**.

*Table 2.1*  
Integration of values and normative orientations  
into innovation management

Area	Description
<i>Traditional approaches to process, product, service, and business model innovation are often missing direction..</i>	Values may provide not only a heuristic function but also a sense of direction. Focussing on values and normative orientations in the context of innovation management unlocks a source for ideation and turns ideas into innovation throughout the decision gates and potential pivots of process stages.
<i>The reflection on, specification of, and dedication to values in the context of innovation...</i>	They are a stronger alignment of innovation activities with organizational visions and missions increasing chances for innovation success in the long run. The normative orientations underlying business activities extend innovation managers' perspectives beyond day-to-day routines and enable an adequate consideration of long-term goals.
<i>The values-based innovation management can help to deal with or even overcome innovation barriers...</i>	Such as non-cooperative behaviour or seemingly insoluble wicked problems (Rittel and Webber, 1973; Waddock, 2013). On a higher level of abstraction, the integrative function of shared values may provide for a common ground among different stakeholders and interests within and outside an organization (Kotter and Heskett, 2011).

Source: Breuer and Lüdeke-Freund (2015) with own adaptation.

Thereby, the innovation managers must be prepared for the *values-based view on innovation management* prerequisites due to the focus on the integration of organizational values with those held by affiliated individuals as well as the wider business environment, offering a new *source, lever and orientation mark* to drive innovation This approach is not to be confused with *value-based management*, which refers to maximizing a company's financial value as a consequence of the shareholder value paradigm (Koller *et al.*, 2010). Instead, *the values-based innovation management refers to values as notions of the desirable that are reflected in personal motivations and evaluations, creative activity, and normative organizational orientations* (Breuer and Lüdeke-Freund, 2015).

### **2.3. The utility of relating values with innovation**

As the concept of innovation sweeps through society, it becomes devoid of meaning and, consequently, *people see no value in innovation itself*. Our aim is to rethink the value of innovation. In order to do so, we aim to define value in a way that makes practical and analytical sense. *At its core, innovation is creation of a new kind of value. Innovation produces value for a certain group of people, an enterprise, an organization, or the larger society.* The most successful innovations are inclusive; they produce value for many parties simultaneously, although the factors associated with value creation and production are different for the various parties involved in and affected by innovation. Value is produced in countless ways, but successful innovations are always based on social value and meaningful difference creation that, in the end, translates or converts into economic value. In practice, ways of defining value are mutually intertwined in ways specific to a particular environment consisting of a tightly interlinked network of actors. (Ruckenstein *et al.*, 2011). In order to create additional economic value, innovations must produce social value and meaningful differentiation. Our general conceptual model proposal offers a new heuristic perspective to deal with phenomena ranging from new product-service development to open innovation. The elaboration of values in management, as first instance, in this section describes the theoretical basis of our values-based view. The following propositions were derived from values and management theories. See **Table 2.2**

*Table 2.2*  
The utility of relating values with innovation

Statement	Description
<i>Every individual and complex social formation holds values...</i>	They occur on every <i>level</i> of social life: individual, organizational, institutional, societal, and global levels (Agle and Caldwell, 1999). Stakeholder interests may be articulated based on more or less shared individual and organizational values.
<i>Values are motivating and attractive...</i>	This includes implicit and explicit values, non-financial and financial values, product-related customer values, brand values, values expressed in vision and mission statements (Waddock and Rasche, 2012), and stakeholder values being created, ignored, and destroyed (Bocken <i>et al.</i> , 2013). A selection of these is contained in the cloud in <b>Figure 2.1</b> .
<i>Multiple notions of values need to be distinguished.</i>	This includes implicit and explicit values, non-financial and financial values, product-related customer values, brand values, values expressed in vision and mission statements (Waddock and Rasche, 2012), and stakeholder values being created, ignored, and destroyed (Bocken <i>et al.</i> , 2013). A selection of these is contained in the cloud in <b>Figure 3.1</b> .
<i>Within organizations values demonstrate different functions.</i>	These can be described as generative (heuristic), directive (orientation), and integrative (affiliation) qualities .
<i>Values can be implicit, shaping individual or group behaviour (especially at the lower management levels).</i>	Within the normative management dimension they tend to be codified and expressed through dedicated statements (such as vision, mission, purpose or values statements, corporate reports, and press releases). Kotter and Heskett (2011) distinguish between rather invisible shared values and rather visible group behaviour.

Source: Breuer y Lüdeke-Freund, 2015 with own adaptation .

Hence, *implicit and explicit values and normative orientations* that exist within business organizations and their environment may and should be used to drive innovation (Breuer y Lüdeke-Freund, 2015). Values can provide a medium for vertical, horizontal, and meta-integration (building on the Integrated Management Concept (Bleicher, 1994 and 2011). See **Table 2.3**

*Table 2.3*  
The values and their utility at normative,  
strategic and operational level

Statement	Description
<i>The values are the base for individuals and organizations for development...</i>	The values are necessary to be measured and classified according the culture of the individual, the organization or the country where they will be applied
<i>Values-based vertical integration aligns normative, strategic, and operational management...</i>	For instance, an orientation towards sustainability can be part of a corporate vision and mission; it can then be pursued as a competitive strategy and instantiated through services and customer communication.
<i>Values-based horizontal integration takes place among collaborators...</i>	Shared values facilitate collaboration and provide a potential basis for teaming up and pursuing a common, values-based goal. For instance, collaborators in an innovation project share an understanding of minimum requirements for sustainability, or agree on and work towards a defined value proposition.
<i>Values-based meta-integration within and beyond organizations...</i>	Organizations need to align with changing institutional, societal, and global values. For example, a shift in governmental energy policy or increasing public awareness of privacy issues can challenge established organizational values and may be included in the normative, strategic, and operational management dimensions.
<i>Values and integrated management are related to open innovation...</i>	Open innovation is a paradigm that assumes that firms can and should use external ideas as well as internal ideas, and internal and external paths to market. It includes the knowledge management, the open business model and innovation ecosystem

Source: Rodríguez-Bravo (*et al.*, 2013); Mejía-Trejo, 2017b; Breuer y Lüdeke-Freund (2015) with own adaptation

We consider, these propositions are transferred to innovation and its management. By doing so, the values-based view relates *values and integrated management to open innovation* (see **section 2.7**). While each of these concepts represents a complex field on its own, it is the unique synthesis of values, management, and innovation that makes up the values-based view on innovation management. It is an emerging field of research and discussion, helping us to better understand how values and their

classification (**EVA protocol** by Rodríguez-Bravo *et al.*, 2013) and normative orientations of them (Breuer y Lüdeke-Freund, 2015) do, may, and should impact and direct innovation and its management, and how they do and may facilitate the creation of new products, services, business models, and networks with open innovation (Mejía-Trejo, 2017 a,b).

#### ***2.4. Values-based innovation as a platform of the strategy***

We assume a normative turn in customer and labour markets as well as in innovation management, which implies a reframing of management frameworks and methods based on a review and codification of values. The values-based view focuses on notions of the desirable and deals with *what we care about* (Frankfurt, 1988) at every level of the organization and its environment. *Innovation literature has long focused on operational issues and the strategic search for competitive advantages.* In both internally and externally motivated cases, establishing a new normative orientation has the potential to generate and direct innovation beyond the competitive advantages and strategic market differentiation that strategists and innovators are usually concerned with. However, in most cases, values and normative orientations have to be explored and developed through research, design, and management. Therefore, appropriate tools and methods are needed to do achieve this (Breuer y Lüdeke-Freund, 2015).

At the beginning of the XXI century, the attention has shifted towards services, business models, and networks and the professionals in innovation management, have leaved to concern only in new processes and products. Encouraged by new internet business models since the 1990s, business model innovation attracted entrepreneurs and academics alike. Not individual products or services, but whole configurations of business model components were identified as a powerful source of innovation (Mejía-Trejo 2017a). Innovation in this sense has often been declared



as, *key to success to gain competitive advantage* (OECD,2005). Many companies have mastered impressive learning curves to conform to pressures to innovate their processes, products, services, and business models. Innovation-driven companies such as Apple, Google,Microsoft, Coca Cola, Amazon, Samsung, Toyota, Facebook, Mercedes Benz, IBM, lead the list of the first ten top most valuable brands (Interbrand, 2017). Consultants, academics, and designers among others, have developed a broad variety of tools to boost the creative capacities of organizations. *However, whether innovation is reduced merely to a strategic means to achieve competitive advantages and differentiation on market-places, innovation misses its purpose, matter, and its full potential,* (Breuer y Lüdeke-Freund, 2015). Accordingly, the values-based view on innovation proposed in our model, moves values and normative orientations from the periphery of business activities to the heart of value creation and innovation. Whereas values and normative orientations can be traced within every business activity, the idea of a normative turn and the concept of *normative innovation* build on the theoretical distinction between operational, strategic, and normative management,as follows:

1. *Normative management* deals with the general purpose of an organization, based on non-economic values and ends. Normative mission statements, purpose, and vision statements reach beyond the typically market-oriented, economic values that dominate the strategic management level. Even though values and normative orientations that exceed economic goals have been increasingly stated explicitly, formulating and realizing such statements is still not a standard practice.
2. *Strategic and operational management* deal with the instantiation and realization of core values through positioning an organization strategically within society and markets and ensuring its operational performance. Amazon's former mission, since 1995: *to be Earth's most customer-centric company, where customers can find and discover anything they*

*might want to buy online, and endeavors to offer its customers the lowest possible prices* (Amazon, 2017) is an example for normative goals that do reach beyond strategic positioning and economic success measures.

Numerous companies striving for increased market share, outstanding customer service, or leadership positions as their *mission* confuse strategic and normative goals. Few companies formulate and communicate such a dedicated normative vision or mission. Indeed, there are companies that use values and explicit normative orientations to drive innovation in processes, products, services, business models, and even networks. Even fewer companies apply the investigation and differentiation of values, purpose, mission, and vision continuously to innovation, such as Arvind Eye Care System (2018) even those that imply the point of view of social enterprises and social innovation (Buckland and Murillo, 2014 and Chilova *et al.*, 2012) where the processes of products and services are renewed, and new business models are established (for instance, based on subsidies generally where regular customers are charged and resources are reoriented to access lower income people).

It is noteworthy that the typical basic strategic concerns, that govern the differentiation of the competitive market are not taken into account, but genuine values of contribution to society that allow serving the base of the pyramid (Prahalad, 2005).

## ***2.5. Values-based innovation results due to its relationships***

Some values such as an orientation towards security, risk reduction, sustainability, accessibility or privacy have been acknowledged to both, *restrict* or *motivate* decision-making in business practice. However, the full potential of values and normative orientations in triggering and directing a new forms of innovation (for instance, open innovation) within companies and

across networks is just being discovered, not only by business organizations but also by non-governmental organizations, private foundations, and social enterprises.

According Breuer and Lüdeke-Freund, (2015) if we putting values first provides integrative, directive, and generative potentials for innovation on all levels. The collaborative exploration and elaboration of values become essential exercises in innovation management. Such an approach is capable of achieving impact beyond the individual company into the value networks and *business ecosystem* they are embedded in with possibilities to the innovation ecosystems, supported by open business models and open innovation (Mejía-Trejo, 2017a,b). *Shared values due of the ecosystems* may provide a common ground among different stakeholders with diverse interests in operational or even strategic concerns within or beyond the individual firm (Breuer and Lüdeke-Freund, 2015).

Values made explicit and mandatory within a project or organization turn into *normative orientations* for innovation in products, services, processes, business models, and networks of cooperating parties. This is the the potential to direct and foster the innovation not only to achieve competitive advantages or strategic market differentiation where the strategists and innovators are usually concerned, but further.

The values-based innovation are always relative: it depends on what is valued. Graeber (2001) proceeds from the premise that a systematic theory of value is hard to find in the theoretical literature. However, he proposes the values-based innovation with three broad perspectives:

- *In the social sense*: understood broadly as the shared ideas of a certain group of people of what is good and desirable in human life and how the community should be organized around these ideas. The political, moral, aesthetic, and other social dimensions of value are shared by the group.
- *In the sense of differentiation* of how different meanings are produced, for example, around a good and desirable life

through various symbolic and linguistic differentiators and concrete actions.

- *In the economic sense:* the desirability of objects or other things, measured especially in terms of the quantity of other things that people are willing to give up in order to gain these. From the innovation standpoint, all three dimensions of value are equally important: a new kind of value will not be created if these dimensions are not in balance. From the innovation standpoint, all three dimensions of value are equally important: a new kind of value will not be created if these dimensions are not in balance. It highlights the inseparable nature of production and consumption and demonstrates how the various dimensions of value are linked with each other and always form an intimate relationship. Dimensions of value support each other; when social value is produced, economic value becomes possible. Innovation creates value by supporting orientations that a certain group of people find good and desirable: that group of people can naturally be defined in various ways (for instance, as a modern-day tribe, a market segment, or a brand or user community). See **Figure 2.1**.

Currently, innovation literature and research tend to emphasize the economic dimension of value. The measurement of economic value is also fairly unambiguous, as it translates into turnover and profit. Innovations are expected to produce monetary value. Yet even if economic value is measured separately from other dimensions of value, its production is, in reality, founded on social value and the supporting meaningful differences. The economic systems are always connected with social relations. This means that economic value cannot be created without mutual trust and various contracts. Ultimately, economic value is social value, and vice versa. (Ruckenstein *et al.*, 2011)

*Figure 2.1*

The three dimensions of value are inseparably interconnected

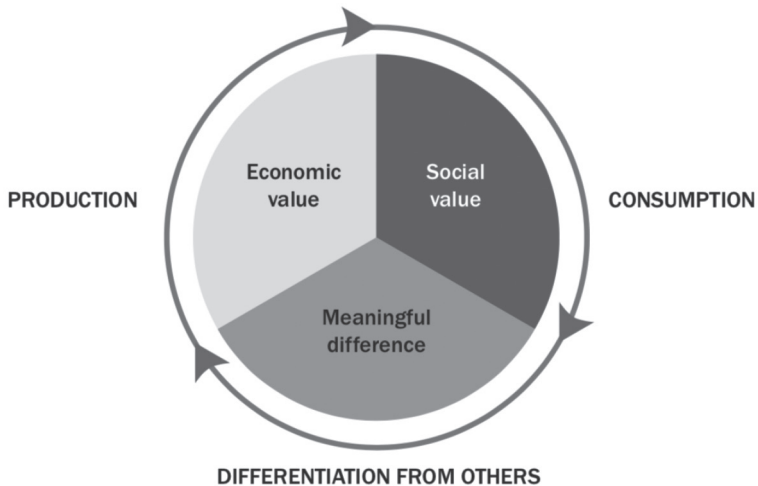

Source: Ruckenstein (*et al.*, 2011).

## ***2.6. Values-based innovation and how is applied in the firm or corporate organization***

Values are not only a given or retarding factor of organizational change, they are also a dynamic element *entering* and *leaving* the firm or the corporate organizations. New values may enter on each management level or dimensión. See **Figure 2.2**.

**Figure 2.2**  
Value-based innovation and how is applied  
in the firm or corporate organization

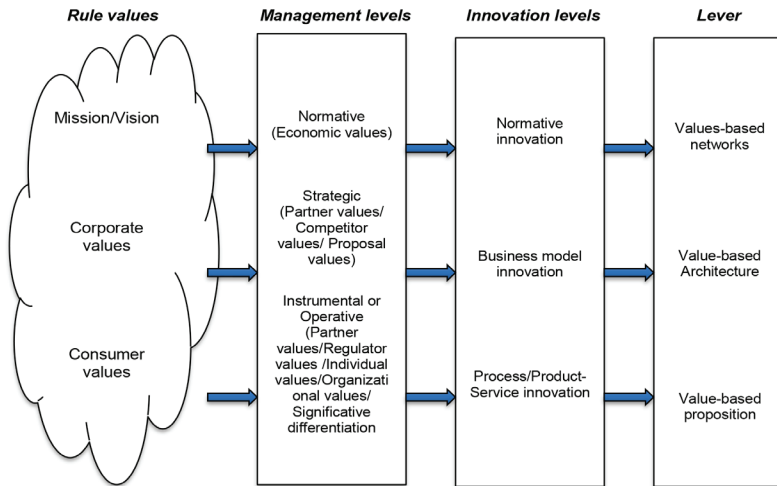

Source: Breuer, H. and Lüdeke-Freund (2015) with own adaptation.

According Breuer, H. and Lüdeke-Freund (2015), the process description is as follows:

1. Top down view, a new board member or CEO may trigger a revision of corporate visions and missions based on her or his individual values.
2. Bottom up, product-related customer values can be taken up by employees to adapt the product portfolio, which might also lead to changes in strategy.
3. A corporate culture project can systematically gather and aggregate values of the workforce to renew or extend an organization's normative statements.
4. In a more strategic perspective initiatives of competitors can set new values-based *benchmarks* such as supply chains aligned to the principles of fair trade.
5. Values leave and transcend an organization through dedicated communication channels and dialogues with stakehol-

ders, but also through the *ask* of products and services, i.e. what a company's products and services ask its customers to become (Schrage, 2012).

6. The exploration and exploitation of values and normative orientations become an integral part of future innovation management. Different kinds of values, on different management levels, lead to different forms of values-based innovation.

On all three management dimensions (according to Bleicher's Integrated Management Concept, see above), and with respect to different stakeholders and entities, different types of values come into play and constitute different levers for innovation. See **Table 2.4**.

*Table 2.4*  
Levels of values-based innovation management

---

<b>Level</b>	<b>Description</b>
<i>Normative management level</i>	It exceeds purely economic concerns and explicitly articulates values that are often implicit in the operational and strategic dimensions. On the normative management level corporate visions, missions and other overarching goals are to be considered, also ethical guidelines for interaction with stakeholders within and outside the company. Corporate mission and vision statements reach beyond the economic goals and values that dominate the strategic management level. Where such explicit statements (or implicit assumptions) and their directives become obligatory and capable to constrain behaviour they become normative orientations and a matter of normative management.

---

Level	Description
<i>Strategic management level</i>	It deals with the development the potential (resources and capabilities) a company needs to engage with its environment and differentiate itself from its competitors. The business model, describing how companies create and capture value, allows for competitive differentiation and mid-term corporate renewal. Whereas environmental and social engagement, for example, may be constitutive parts of a business model, systematically using it as a basis for innovation (Breuer, 2013) requires consistent values-based decisions, thorough elaboration, and normative dedication – each to be facilitated by suitable collaboration methods and activities. Relevant values on the strategic level include rather implicitly grown orientations like the ones identified by Jones (2002). He describes how product innovation can be (de-) prioritised depending on earlier product innovation success (which might devalue innovation and its associated risks in comparison to market skimming and differentiation strategies), leading to an emphasis on process rather than product innovation. Reflections to increase awareness of such strategic orientations and leadership commitment to innovation are prerequisites also for values-based innovation. <i>It is primarily concerned about competitive advantages</i>
<i>Operational or instrumental management level</i>	The level product and service-related customer values are addressed by value propositions (and their underlying offerings) and related marketing instruments. Changing customer values and new value propositions addressing them can be a basis for innovation in process, product, or service offerings as well as further marketing instruments and business model components.

---

Source: Breuer, H. and Lüdeke-Freund (2015) with own adaptation.

Levers and intended results of innovation are derived for the three management dimensions (for instance, operational or instrumental innovation, including innovation in product and service offerings and marketing instruments), strategic business model innovation, and normative innovation to develop new identities and create new values-based inter-organizational networks. Many companies have introduced new positions and departments to manage corporate social responsibility (CSR) and sustainability issues, but even these activities rarely develop meaningful relations with innovation management (Breuer, H. and Lüdeke-Freund, 2015). See **Table 2.5**.



**Table 2.5**  
Values-based innovation management levers

<b>Lever</b>	<b>Description</b>
<i>Normative (value-based networks)</i>	New values introduced to the normative dimension – e.g. initiated by a new CEO, a change of mind of the board of directors, or changing societal expectations and regulations touching the <i>identity</i> of a company – are expressed as values-based innovations such as new corporate visions and missions, new codes of conduct and policies. Beyond the focal firm new values-based networks may emerge, e.g. among heterogeneous and even competing organizations dedicated to the vision of a renewable energy región. Innovation on a normative management level can also be motivated by changing values on the strategic and operational dimensions.
<i>Strategic (value-based architecture)</i>	Strategic innovations refer to changes in the preconditions of a company's <i>competitive advantage</i> and its associated strategic goals due to the introduction of new values on the strategic dimension. In recent years, business model innovation has been discussed as a silver bullet to innovation in a strategic management dimension. Strategic values-based innovation and goals (e.g. from <i>we want to outperform competitors based on price</i> to <i>competitive differentiation and outperformance in terms of sustainability contributions</i> ) may be triggered by new sets of values established on a normative level. However, strategic innovations can also be motivated by changing values on the operational dimension.
<i>Instrumental or Operative (value proposal)</i>	Operational innovations refer to changes in operational processes and the associated way of doing business; operational innovations can be motivated by changing values on the normative and strategic dimensions. Each marketing instrument on the operational level can introduce new values adapted from customers.

Fuente: Breuer, H. and Lüdeke-Freund (2015) with own adaptation.

## **2.7. Values-based innovation and other similar terms**

The discourses on *responsible innovation*, *sustainability innovation* have taken the first steps to explore these relationships between particular values, such as ecological justice and respect for future generations and innovation (Owen *et al.*, 2013). In this sense, we see that values-based view is seemingly besides, a close relative of *social innovation* and *eco-innovation*. See **Table 2.6**.

**Table 2.6**  
Values-based innovation and other similar terms

<b>Term</b>	<b>Definition</b>	<b>Author</b>
<i>Values-based innovation</i>	The values-based view on innovation focuses on the role of values and normative orientations in triggering and directing innovation within and beyond organizations..... ...Values-based innovation refers to values,for instance: notions of the desirable, held by individuals or a social group that provide a basis for inspiring, directing, and evaluating innovation.That is, values may fulfil integrative, directive, and generative functions for and within innovation projects...	Breuer, H. y Lüdeke-Freund (2015)
<i>Responsible innovation</i>	It is the relationship of how corporate social responsibility goes to innovation that considers doing the right things in employees, customers, supply chains, etc. (doing things right) and how innovation goes towards corporate social responsibility, making things right, respecting the environment and the community, etc. (doing the right things) ...	Alejos (2015)
<i>Sustainability innovation</i>	It is a process where sustainability considerations (environmental, social, financial) are integrated into the company's systems from the generation of ideas to research and development (R&D) and marketing. This applies to products, services and technologies, as well as new business and organizational models. They have four levels: incremental, redesign or green boundaries, functional or alternative products and systems ... .. It tries to reduce or avoid negative effects on the natural environment and society with the creation of positive effects, such as ecological restoration or the provision of education and health care services ...	Martin y Clark (2009); (Hansen <i>et al.</i> ,2009)
<i>Social innovation</i>	It is the set of plans, policies, agreements, social mechanisms, forms of civil society organization that create new and successful services and processes aimed at the solution of specific social problems ....	Hernández-Ascanio <i>et al.</i> (2106)
<i>Eco-innovation</i>	It is any form of innovation that points to a significant and demonstrable progress towards the goal of sustainable development, by reducing the impacts on the environment or achieving a more efficient and responsible use of natural resources, including energy...	Martin y Clark (2009); Owen ( <i>et al.</i> ,2013)

Source: several authors with own adaptation.

Values-based innovation is not only an issue for green entrepreneurs or idealists or social defenders, but a *potentially powerful lever for every business*. A company's values are *both explicitly and implicitly articulated in operative and strategic decisions, manifested in interactions and relations to stakeholders, and contained in companies' offerings*. The values landscape create unique opportunities, but also threats to deal with. *Exploration, revision, and elaboration of values bear the potential to align what business is about to what is important to its agents* (Rodríguez-Bravo et al., 2013).

Such clarification, is necessary to simplify business on its essential values and purpose. *Values seen as enablers and drivers of innovation, and not as mere constraints to creativity and development, contribute to a normative turn in innovation management*. (Breuer, H. y Lüdeke-Freund, 2015).

Other important difference, is that the values-based view proposes a more basic innovation theory, that forseees and avoids the results of *undesired* innovation (for example, results that tend to threaten the economy and / or finances of a sector, the integrity of ecological and social systems, the incongruence of values with the results obtained in innovation policies, etc.). In this regard, there are cases where values of the environment external to the organizations, press for innovations. Such is the case of Mexico, where public pressure causes the prohibition of animals in circuses, a circumstance that forces them to offer new variants of spectacle (Millennium, 2014), highlighting in turn, that the innovations produced consequences not provided as the case of the uncertainty of animals seized by such measure (Televisa.news, 2018). In contrast to the concepts of *responsible innovation and sustainability innovation*, the values-based innovation is *non-prescriptive with regard to particular values*. In addition, to avoid *undesired* innovation outcomes, for instance, the values-based view focuses on the generative potential of notions of the desirable and asks for *what we care about*. A values-based methodology reframes and repurposes existing innovation tools

and methods. Future scenarios not only allow us to explore and prepare for potential futures, but also to imagine desirable futures to stand up for.

Finally, values-based business model innovation (Mejía-Trejo 2017a) becomes an approach to solve societal problems and to realize ideals by the means of business with the platform of values-based innovation view. Combining these approaches, individual companies and networks may take a normative turn towards innovating by what we care about, in individual, organizational, and societal values and accordingly in what individuals, organizations, and societies are striving for (Breuer, H. and Lüdeke-Freund (2015). It is not primarily about adhering to the constraints of given values and mandated norms, but taking values as a basis and heuristic to systematically explore and exploit new innovation opportunities and even to address the *wicked problems* of our time (Rittel and Webber, 1973; Waddock, 2013).

## ***2.9. Values-based innovation and the integrative function operation***

Instead of focussing on an exchange of individual ideas, perspectives, or pieces of knowledge, the values-based innovation takes values as a basis and medium for joint projects, involving internal and external actors in search for solutions to urgent problems or new ways to realize their ideals (Breuer, H. and Lüdeke-Freund, 2015). With respect to their *integrative function* values form ordered systems of priorities and relative importance (Schwartz, 2012). This hierarchical feature allows the inclusion of diverse subordinate values in the joint pursuit of overarching values. Appealing to overarching values that different counterparts share is also a method of resolving values-based dispute (Susskind and Rose, 2010). Values run right through the hearts of the actors sharing them, pervading human beings and even things. *Values achieve integration more than distinction, in*

other words, values of individuals or groups are either shared or can be related through overarching values; in the worst case of *unshared* values, they lead us to reflecting them and acknowledging those of others.

## **2.10. Values-based innovation and open innovation**

The *integrative function* predisposes values to not only facilitate horizontal, vertical, and meta-integration internally, but also externally, pushing an open innovation paradigm (Chesbrough, 2003; Mejía-Trejo, 2017b) that builds on a rich exchange of internal resources of the firm with external actors and diverse sources of knowledge. Open innovation is *a paradigm that assumes that firms can and should use external ideas as well as internal ideas, and internal and external paths to market* (Chesbrough, 2003). The open innovation model suggested by Mejía-Trejo (2017b), represents a very interesting approach to complement the value-based view by Breuer, H. and Lüdeke-Freund (2015) at lever stage. See **Figure 2.3**.

Figure 2.3  
Open innovation model as lever stage

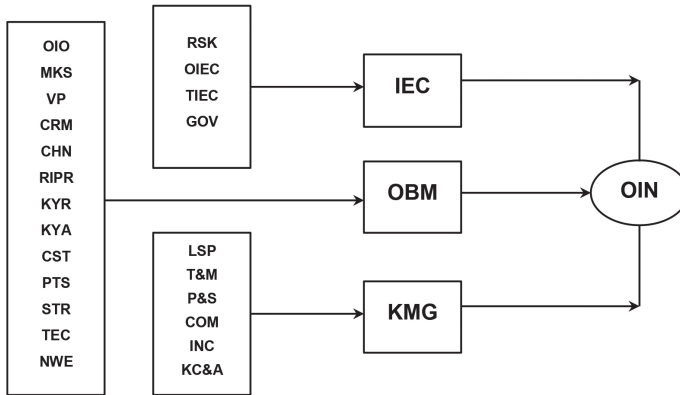

Source: OBM Model Mejía-Trejo (2017 a) and OIN Model Mejía-Trejo (b).

Notes: **LSP**.-Leadership ; **T&M**.-Training and Mentoring; **P&S**.- Policies and Strategies; **COM**.-Communication ; **INC**.-Incentives; **KC&A**.-Knowledge capture & acquisition; **OIO**.-Open Innovation Orientation; **MKS**.-Market Segmentation ; **VP**.-Value Proposition; **CRM**.-Customer Relationship; **CHN**.-Channels of Distribution; **RIPR**.-Revenue Streams for Intellectual Property Rights; **KYR**.-Key Resources; **KYA**.-Key Activities; **CST**.- Cost ; **PTS**.-Partnership; **TEC**.-Technology ; **STR**.-Strategy; **NWE**.-New Entrepreneurships. **RSK**.-Risk; **OIEC**.-Opportunities of Innovation Ecosystem ; **TIEC**.-Threats of Innovation Ecosystem; **GOV**.-Governance.

**OIN** is defined as *a distributed innovation process based on purposefully managed knowledge flows across organizational boundaries* (Chesbrough and Bogers, 2014). Hence, the open model innovation (Mejía-Trejo, 2017b) proposed here consists in:

### 2.10.1. Innovation Ecosystem (IEC)

It is considered as: *a network of interconnected organizations, organized around a focal firm or a platform, and incorporating both production and use side participants, and focusing on the development of new value through innovation* (Autio and Thomas, 2014).

This **IEC** in our model is proposed with the next elements to analyze: Types of risk (**RSK**) such as: cost, the infringement litigation with other companies in a similar and/or different product markets, etc. (OECD, 2008). The opportunities (**OIEC**), based on: the potential on how well knowledge flows and the system is connected, a greater sense of urgency for internal groups to act on ideas or technology (OECD,2008; Lichtenthaler 2009). The threats (**TIEC**) such as: the extra costs of managing co-operation with external partners, the lack of control, the potentially opportunistic behavior of partners, (Goglio-Primard and Crespin-Mazet, 2014), the adverse impact of flexibility, overdependence of partners, etc. (Lichtenthaler 2009). A governance system (**GOV**) able to be elected and recognized, as a key factor for applying the principles of behavioral rules that support and regulate all the transactions by mean of written rules, the process of election of central governance, establishing roles and responsibilities to take decisions, etc. (Deloitte, 2015).

### *2.10.2. Open Business Model (OBM)*

We consider the Osterwalder and Pigneur (2010) definition of business model: *A business model describes the rationale of how an organization creates, delivers, and captures value.* Hence, with the increased adoption of open innovation practices, *open business models* have emerged as a new design theme (Chesbrough, 2007). Therefore, we propose an **OBM** concept associated with **KMG** necessary to potentiate the **OIN** Orientation (**OIO**) by the definition of exploring it, as the experimenting with new alternatives and/or exploiting it, as the refining and extending of the existing knowledge (Chien-Tzu and Wan Fen, 2014,) and what kind of driver is using, such as: the purchase of technology, licensing, purchase of technology, etc. (OECD, 2008). The market segmentation (**MKS**) as the basis to define the services and products specialized to offer to the customer (Osterwalder and Pigneur, 2010) and represents the opportunity to analyze,

different applications of the technology besides the current market such as the discovering and developing new markets or for licensing other firm's market (OECD, 2008; Chesbrough 2003). The value proposition (**VP**) is the core of any business, so it should be emphasized in different forms, such as: branding, performance, newness, etc. (Osterwalder and Pigneur, 2010; Mejía-Trejo *et al.*, 2013) and make the user a source of innovation *to create value*, as a tool to *capture value* (Chesbrough 2003). The customer relationship management (**CRM**) as a tool, must be applied in different channels (**CHN**) (by own and/or partners), in all its different forms, such as: personal service, automated-service, self-service, etc. (Osterwalder and Pigneur, 2010; OECD, 2008) emphasizing the co-creation (Rayna and Styriukova, 2014) in network. The revenues streams (**RIPR**) represent a great chance, for the organizations based on de intellectual property rights (**IPR**) protection as: patents, trademarks and copyrights, for commercializing them using patent pools or cross-licensing portfolios, for instance (OECD, 2008). The key resources (**KYR**) must be recognized (Osterwalder and Pigneur, 2010) involving tangible (buildings, infrastructure, labs, etc) and intangible (data, information, talent personnel, etc.) assets. The Key Activities (**KYA**) mainly the R&D network, be more productive based on absorptive capacity features, knowledge and technology (OECD, 2008). The minimum of the costs (**CST**), like fixed-cost, variable-cost, economy-scale, economy-scope, etc. (Remneland-Wikhamn and Knights, D. 2012). The Partnerships (**PTS**) represents a solid base to make business, involving the relationship University-Government-Organization-Society (Quadruple Helix) (OECD, 2008, Miller *et al.*,2016). The technology (**TEC**), due its capacity to incorporate it in an external or internal way to the organization and aimed to the current or different markets (Chesbrough, 2003).The strategy (**STR**) applied in different ways: Market-Based Innovation; Crowd-Based Innovation Strategies or Collaborative Innovation;Network-Based Innovation Strategies (Gassmann et al.2010) according differ-



ent final goals to implement, such as: improvement of revenues, performance, competitive advantage, or even more, ensure the secrecy, etc. (OECD, 2008). Finally, the new entrepreneurships (NWE) successfully achieved are a good indicator of any OBM, such as the *spin-in*, *spin-out* and *spin-off* in certain period (OECD, 2008).

### 2.10.3. Knowledge Management (KMG)

According the OECD (2003): *It covers any intentional and systematic process or practice of acquiring, capturing, sharing, and using productive knowledge, wherever it resides, to enhance learning and performance in organizations.* Hence, we propose a model based on a strong leadership (**LSP**) of its members (OECD, 2003; Mejía-Trejo *et al.*, 2013) able to establish different mechanisms of communications (**COM**) to transmit the explicit and tacit knowledge, including training the personnel and mentoring the apprentices (**T&M**) with policies and strategies (**P&S**) about rewards and incentives to the personnel (**INC**) in inbound and outbound knowledge frontiers of the Firm (OECD, 2003; Asakawa *et al.*, 2010; Hughes and Wareham, 2010; West and Bogers 2014). To do a best knowledge capture and acquisition (**KC&A**) (Gassman and Enkel, 2004; OECD 2003; Goglio-Primard and Crespín –Mazet, 2014; Keup and Gassman, 2009), the incentives to the personnel are recommended (OECD, 2003; Allarakhia *et al.*, 2010).

# Chapter 3

## A general conceptual model proposal

With all mentioned above, we propose the following model, based on the gathering of all the previous models revised, and showed in **Table 3.1**.

*Table 3.1*  
Constructs of the general conceptual model proposal

Construct	Description	Author
Value-Based Innovation Model	<p>Value-Based Innovation (see <b>Section 2.6</b> and <b>Figure 2.2</b>) process divided in:</p> <ul style="list-style-type: none"> <li>-<i>Horizontal sense</i> in normative, strategic and instrumental/operative management and innovation levels</li> <li>-<i>Vertical sense</i>, involving the values in top-down since innovation level in top-down view the director board, the business model and the internal process of the corporate organization to the process-product and service innovation.</li> </ul> <p>So far the moment, when this book is written, <i>the values-based view and the theoretical framework sketched out in this paper raise more questions than they provide definitive answers...However, a rich collection of empirical action research cases studies is needed to further differentiate the approach and to explore its full potential and limits.</i></p> <p><i>The integrative function predisposes values to not only facilitate horizontal, vertical, and meta-integration internally, but also externally, pushing an open innovation paradigm ...Description of open business model (Mejía-Trejo, 2017a) and open innovation model (Mejía-Trejo 2017b) as a lever stage (See <b>Section 2.10</b> and <b>Figure 2.3</b>) Both models have been empirically implemented.</i></p>	<p>Breuer, H. and Lüdeke-Freund (2015);</p> <p>Mejía-Trejo (2017 a-b)</p>

Construct	Description	Author
Eva protocol	<p data-bbox="364 249 856 804"><i>This research is aimed to determine the main values-based innovation in a Industry or sector able to focus the human resources in the organizations, to encourage the innovation with higher impact and accurate results for competitiveness, based on in a benchmarking of successful worldwide firms to be applied in Mexico and Spain (as an example, the most innovators firms , no matter what industries or sectors are being).</i> The model works as a preliminary stage to <b>EVA protocol</b> supported with the opinión of experts under Delphi's focus group analysis. The final results, were: <i>82 different values-based innovation</i> (including 4 added as suggestions of experts vision), distributed in a conceptual model in Innovation Level, with 3 main sub-areas, called: Normative Innovation (Production); Business Model Innovation (Consumption); Process/Product-Service Innovation (Differentiaton from others). These results are the first insights in Mexico, to be assessed in a complementary study in Spain to obtain a value-based innovation generalized model in a subsequent study. See <b>Chapter 4</b>.</p> <p data-bbox="364 821 856 1245">The model is aimed to determine an <i>iberoamerican inventory of educational, social and human values</i>. The original study consisted in the analysis of the Declaration of Human Rights (1948), and the Federal Constitution of Brazil 1988) and the Constitution of Spain (1978), to determine such values inventory. The following steps were aimed for designing a protocol to assess and measure the values (process detailed in <b>Section 3.2</b>), Qualitative validation of the protocol to assess and measure the values, the designing and the application of test served to generate the main parameters for values(see <b>Table 1.6</b>): intensity of value; mode statistic; coherence; reliability and power of value and global load of value. The final results were 26 inventory values classified in educational, social and human values.</p>	<p data-bbox="876 249 988 297">Mejía-Trejo (2017c)</p> <p data-bbox="876 821 988 894">Rodríguez-Bravo (et al., 2013)</p>

Construct	Description	Author
Value-Based Management	Value-Based Management is a company's management approach to value creation, particularly by maximizing shareholder value. Management's planned strategies can have a major impact on future actions of stakeholders, so that management should take into account their interests in parallel with the interests of stakeholders (See <b>Figure 1.4</b> )	Robu and Ciora (2008);
	It highlights the importance to define the meaning and scope of the concepts: <i>productivity, efficiency and effectiveness</i> as indicators of values-based management.	Jaakson (2010)
	Attention is drawn to the fact that the model not only addresses the construction client's needs, but all the interested parties' needs. The interested parties' needs should be perceived widely. The model emphasizes: efficiency and effectiveness. See <b>Figure 1.5</b>	Bruzelius and Skärvad (1989);
	<i>The main lack, however, is that productivity does not take into consideration whether it is the right product we produce, and furthermore, no indications of who the buyer is . That is why productivity is inadequate to measure the full potential of values-based view, and, therefore, why we should use efficiency and effectiveness as indicators of innovation and development.</i> (Wandahl, 2004).(See <b>Section 1.4.1</b> ). The importance of comprehending the difference between efficiency and effectiveness (see <b>Figure 1.3</b> ). Effectiveness is an expression of the level of correspondence of the specifications with the interested parties' needs. Efficiency has two dimensions. Firstly, the achieved specifications are compared with the needed specifications, and secondly, the production of these specifications compared with the level of used resources. To put the efficiency / effectiveness differentiation into perspective, a model using a product / process viewpoint can be helpful. See <b>Figure 1.6</b> .	Wandahl (2002, 2004);
	There are two sets of values in the <i>value-based management: product value and process value</i> (see <b>Figure 1.7</b> ). These are the basis of <i>management by values and/or management of values</i>	Wandahl and Beijder (2003);

Author: several authors with own adaptation.

It is important to emphasize this conceptual model proposal, that never has been implemented and proved more than only in three of its constructs. They are, the findings of:

- *Mejía-Trejo (2017 a, b) as part of the open business and open innovation process, in the general conceptual model proposal.*
- *Mejía-Trejo (2017c) as a proposal for determining and weighting the values-based inventory as a preliminary stage of **EVA protocol** (explained in detail chapter 4).*
- *Rodríguez-Bravo (et al., 2013) showed in detail in the following lines below and posed as analogy to be implemented in the stage of weighting and selecting the values-based innovation inventory*

Thereby, it is only the interest of this book to describe the empirical studies supporting the construct of **EVA protocol**, in the determining, measuring, weighting and selecting values inventory as a general process. See **Figure 3.1**.

### **3.1. How does it work?**

The **Figure 3.1** illustrates lines of potential integration and also potential dispute between organizational instances in different (*normative, strategic, and operational*) management and innovation levels with surrounding actors and values systems. Establishing a unique perspective as results on *open innovation management*, the values-based view grounds new approaches to dealing with some of its challenges. Taking the *integrative function of values* and considering *the three innovation management dimensions*, the values-based view allows for theoretical explanations and empirical investigations of diverse phenomena at the intersections of values, innovation, and management; for example:

- *How shifting values at the board level motivate new business processes (through vertical integration from *the normative to the strategic and onto the operational level*)?.*

**Figure 3.1**  
The values and how they are related in the organization with open innovation

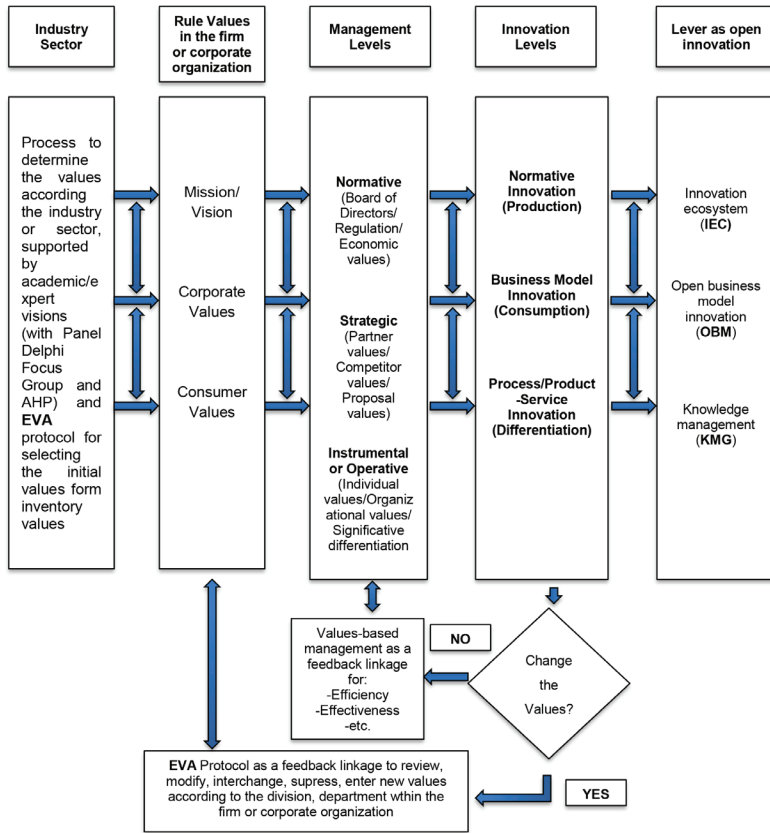

Notes:

- .- Integrative horizontal coherence function;
- .-Integrative vertical congruence function

Source: Rodríguez-Bravo (*et al.*, 2013); Mejía-Trejo, 2017 a-b; Breuer, H. and Lüdeke-Freund (2015) with own adaptation.

- How customer values experienced at the very front (for instance, sales and services) can lead to new strategies and maybe even corporate policies (through *vertical integration*)?
- How a board of directors shares the same belief of what the company shall achieve, or how an innovation team deals with sustainability (through *horizontal integration*).
- How the competitive spirit of a particular industry can motivate CEOs as well as process engineers (through *meta-integration*). In the proposal model, exists a point of decision asking: *Change the values?*

To solve these questions, In the proposal model exists a point of decision asking: Change the values?

*If the answer is Yes the values will be reviewed, modified, interchanged, suppressed or entered as a new set up to the firm or corporate organization, thereby is applied the **EVA protocol** criteria.*

*If the answer is No the values will remain operating and reviewing the key performance indicators, hence, is applied the value-based management, mainly based on Effectiveness and Efficiency criteria. (See **Section 1.4** )*

To understand the process when the answer is Yes, we offer the explanation of how it works the proposal model in the following sections.

### **3.2. EVA protocol where valuing starts**

According the study of Rodríguez-Bravo (*et al.*, 2013), the main objective of his research was to determine an *iberoamerican inventory of educational, social and human values*, with two conditions:

- a. It must be independent of the values model of each one of the researchers

- b. It must be functional, despite the existence of geographical, sociopolitical and cultural differences of the subjects that use it

Consequently, the chosen sample should be aligned to these characteristics.

The study was broken in four stages, explained as follows:

### *3.2.1. Selecting the values for inventory*

The fact of centering the construction of the inventory in the search of concrete documents of any word or phrase associated with a predefined concept of value, reasonably guaranteed the independence of the subjective value model of the researchers. *But what should the sample documents be?* One of these documents worldwide recognized and selected for the study, was the Declaration of Human Rights (1948). However, there are different local documents that act as a general reference on values in the current democratic states and one of them, are their constitutions. In this sense, it was considered essential to include a minimum representation of constitutions that guaranteed the extension of the model to more than one specific geographical, socio-political and cultural area. Based on this second criterion, it was decided to limit the content analysis to: Federal Constitution of Brazil (1988) and Spain Constitution (1978). Hence, the decision to study the values model of their respective countries, according to the following steps:

- Reading and exploration of the reference documents;
- Location of fragments where the values appear;
- Extraction of the values in the form of a keyword;
- Confrontation with the globality of the inventory;
- Definition of the values taken from a reference dictionary;
- Final definition of the values;
- Development of the values.



### 3.2.2. Determining the values

As a result, there were determined 26 values, as is showed in **Table 3.2.**

*Table 3.2*  
The 26 Values based on Declaration of Human Rights,  
and the Constitutions of Spain and Brazil

Values	
1	Health (Salud)
2	Responsibility (Resoponsabilidad)
3	Respect (Respeto)
4	Progress (Progreso)
5	Pluralism (Pluralismo)
6	Peace (Paz)
7	Order (Orden)
8	Moral/Honor (Moral/Honor)
9	Liberty (Libertad)
10	Justice (Justicia)
11	Intimacy (intimidad)
12	Independency (Independencia)
13	Equality (Igualdad)
14	Identity (Identidad)
15	Family (Familia)
16	Effort (Esfuerzo)
17	Equity (Equidad)
18	Education (Educación)
19	Dignity (Dignidad)
20	Rights (Derechos)
21	Democracy (Democracia)
22	Duties (Deberes)
23	Culture (Cultura)
24	Cooperation (Cooperación)
25	Well-being (Bienestar)
26	Friendship (Amistad)

Source: Rodríguez-Bravo (*et al.*, 2013) with own adaptation.

A process of values classification was applied under three possible components: *educational* (related with the actions aimed to perfect the intellectual, moral and physical faculties of the human being), *social* (related to the support of the social insertion, the defense of the human rights and the diffusion of the services of the human being in the social organizations) and *human* (related to the defense of dignity, the satisfaction of needs and the physical and mental development of the human being.).

### *3.2.3. The designing of protocol to assess and measure the values.*

This is based on test over the subjects allowing the comparison of the load values able to transmit any process of social communication. Firstly, according the **Section 1.8.1**, it is necessary to start, with previous creation of a list of values appropriated to be applied in a *selected division at the firm or corporate organization* (for instance: the management board; marketing & sales, engineering department, etc.) as a proposal of each innovation level (Normative/Business Model/Process-Product-Service innovation) in the model, *and assessed by a focus group of experts in specialized processes* (for instance: making decision process, designing of business models, innovation in product-services, etc.).

### *3.2.4. Qualitative validation of the protocol to assess and measure the values.*

The next stage is the design of a tool that allows to weight and identify the load of each one of the values selected, perceived for the specialists, to be validated , aligned and applied in such specialized processes according the **EVA protocol** procedure as is showed in the **Table 3.3**.

**Table 3.3**  
**EVA protocol: Validating the tool**

Stage	Objective	How to achieve it
EVA protocol applying and measurement of values for a selected division at the firm or corporate organization	a) Check the degree of coherence of the results of the measurement among the selected division groups. b) Detect problems in the dynamics of the procedure and make correction due eventual failures.	Applying the <b>EVA protocol</b> with measurement of values by mean of the communication of different messages for instance, to the board of directors, managers, etc. It can be supported by Delphi Focus Group.
EVA protocol applying and measurement of values for a group of experts in specialized processes	a) Validate the protocol definitively correcting the possible overlap that may exist between the different inventory values. b) Measure the extent realibility	Applying the <b>EVA protocol</b> with measurement of values by mean of the communication of different messages (it is possible to use the same material showd for the first stage) for instance, to the marketing & sales or design & engineering departments. It can be supported by Delphi Focus Group.
Glossary of terms	The subjects under study must knowledge the correct definitions of values expressed in the test, based on a glossary of terms.	Glossary of terms, previously delivery and studied.
Test	The subjects under study, receive a booklet containing the test of each value to be under analysis (one spot or advertasing, suggested per value or a set of values). The test is designed using the classic <i>Osgood Differential</i> format with the assessment of each value under study.	<ol style="list-style-type: none"> <li>1. Delivery of materials.</li> <li>2. Explanation of objectives and way of working.</li> <li>3. Projection of a training spot.</li> <li>4. Argumented evaluation of the values of the training spot and completion of the corresponding test by the monitor.</li> <li>5. Projection of the first spot to evaluate</li> <li>6. The monitor requests the test response, waits and checks that the entire group have enough time to answer the test before projecting the next spot. If one of the subjects requests it, the projection is repeated.</li> <li>7. Repeat the cycle until all the spots are evaluated.</li> <li>8. Collection of the booklets with the answers.</li> </ol>

Source: Rodríguez-Bravo (*et al.*, 2013) with own adaption.

### 3.2.5. Designing the test

The Rodríguez-Bravo's (*et al.*, 2013), research considered five spots to transmit values. See **Table 3.4**.

*Table 3.4*  
Spots of Rodríguez-Bravo's (*et al.*, 2013) study

Spots	Description
<i>Danet</i> (Test for training)	This is the announcement of Danone's custard called Danet. It is shown as a fictional character (superhero) bursts into the room of a teenager in a boring attitude and is dedicated to destroying the room (including the alarm clock) while the young man looks at it very astonished ; Meanwhile, his speech is as follows: <i>Crunch your routine, do not let routine grind you.</i>
<i>Monos</i>	The Solidarity Marathon of the Television of Catalonia is announced, for which a laboratory is shown, where the abilities of two monkeys are experienced. The first did it wrong and does not receive a prize, while the second guesses right and gets a banana that, in a heartfelt way, decides to share with his partner. An emotional song about friendship plays all the time.
<i>Actimel</i>	It is an everyday scene in an office, where an employee speaks on the phone to loud shouts, emphasis and gestures. Suddenly, a companion rises menacingly from his desk and violently destroys the girl's telephone set in front of her. The employee leaves the field. Immediately afterwards, the aggressor also leaves the field in the same direction as the girl. At the end of the story, the product is offered as an alternative to stress.
<i>Niños</i>	It announces the organization <i>Child Friendly</i> in defense of children, through different negative actions of different adults (domestic violence, stress, insensitivity to the weakest, violence in traffic, throwing a can in the street ...) that are imitated simultaneously by the children who accompany them. The spot closes with a positive example action and voiceover reminding that children imitate adults in everything.
<i>Pinguinos</i>	It is an animation spot in which a father / mother penguin and his three young are on a tiny island. It reveals an unpleasant and incessant chirping of the three pups; the father, impassive, kicks a penguin into the water; Then a shark passes by where it fell. The two little penguins are instantly silent and tremble in panic, but moments later they gradually reinitiate the noisy and annoying previous chirping and a superimposed text appears with the phrase <i>72% of couples are stressed</i> . Finally, the name and logo appears: <i>Condomshop.org</i> .

Source: Rodríguez-Bravo (*et al.*, 2013) with own adaptation.

### 3.2.6. *Validating the tool*

Application of the **EVA protocol** and the measurement of values for a group of experts in specialized processes, as follows:

- a) Validate the protocol by definitively correcting the possible overlap that may exist between the different inventory values.
- b) Measurement of the reliability degree.

Application of the **EVA protocol** with the measurement of values through the communication of different messages (it is possible to use the same material shown for the first stage), for example: in the marketing and sales or design and engineering departments. It can be compatible with Delphi Focus Group.

The subjects under study must know the precise definitions of the values expressed in the test, based on a glossary of terms, previously delivered and studied. Also, the subjects under study receive a booklet containing the proof of each value that will be analyzed (a spot or advertisement, suggested by value or a set of values that expresses a value or a set of values).

### 3.2.7. *The test contrast*

In order to study the effectiveness and quality of **EVA protocol**, it is necessary to select two or more homogenous groups of subjects (suggested at least 5) with the following characteristics must be selected for the test: all the subjects must be experts (from selected división at the firm or in a specialized process, and representing two important views: the theoretical (academic vision such as: Doctors, Professors, Consultants, etc.) and empirical (practical visión, such as: Engineers, Supervisors, Managers, etc.) views.

The messages containing the values under analysis, are suggested to be applied in audiovisual mode and they must be chosen to be assessed and measured, base on different advertising spots.

Since the central objective of this stage of the research is evaluative, the units of analysis should correspond to paradigmatic cases of the presence of values in audiovisual content: *clearly positive, clearly negative, or clearly contradictory*. Advertising spots must be chosen with complete and brief audiovisual messages, capable to arouse a great controversy about their content in values.

Using a support software (such as **Excel** or **SPSS**) **EVA protocol** shows both parameters to be assessed: *power of value* and *global load of value* from obtained from the test values, fulfilling the conditions showed in **Table 3.5**.

*Table 3.5*  
Power of value and global load of value

---

Comparative assessment of <i>power of value</i> and <i>global load of value</i> among the spots
Comparative assessment of <i>power of value</i> and <i>global load of value</i> among the expert groups
The adaptation and reformulation of the working hypotheses to specific parameters of measurement, as follows: -The results corresponding to the <i>same spot</i> , when they are assessed by <i>different groups of experts</i> , should be clearly similar to each other. -The results corresponding to <i>different spots</i> , when they are assessed by <i>the same or different groups of experts</i> , should be completely distinguished to each other.
It is important to generate diagrams and/or graphics to show the results of each one of the values under study in positive, negative or contradictory mode.

---

Source: Rodríguez-Bravo (*et al.*, 2013) with own adaptation.

### 3.2.8. Results

As result of the test development mentioned above, we show the eight graphics containing responses of *value power* (*potencia de valor*), *reliability* (*confiabilidad*) and *global load of value* (*carga global de valor*) calculated according with the **EVA protocol** parameters (detailed in **Table 1.6**). See **Graphics 1 to 8**.

Graphic 1  
Spot Monos Group 1

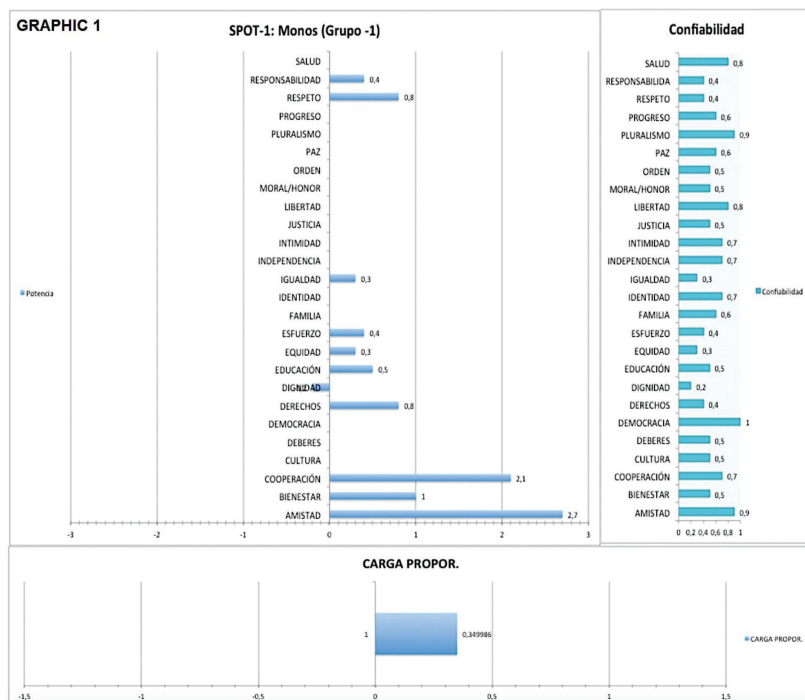

Source: Rodríguez-Bravo (et al., 2013).

Graphic 2  
Spot Monos Group 2

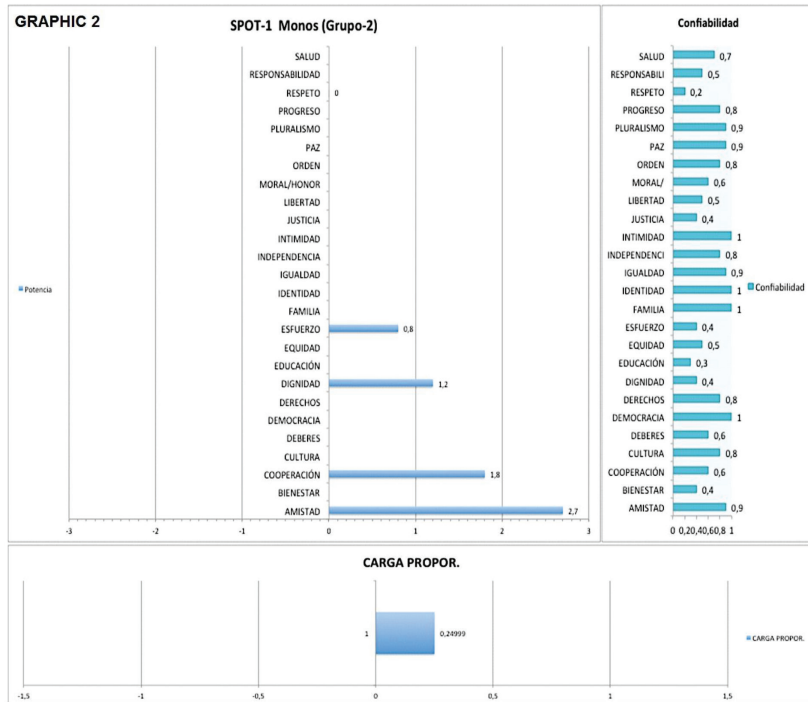

Source: Rodríguez-Bravo (et al., 2013).



Graphic 3  
Spot Actimel Group 1

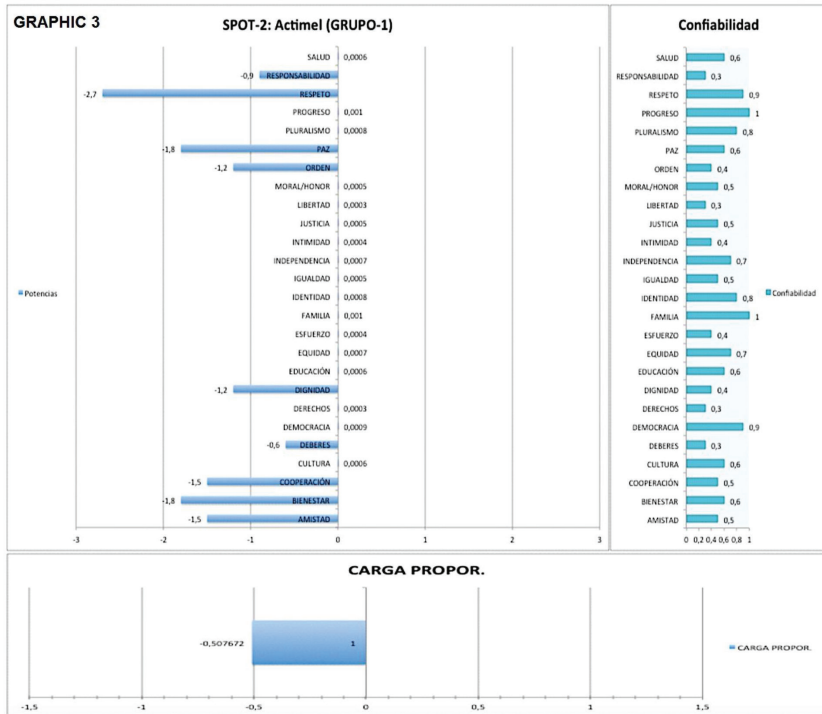

Source: Rodríguez-Bravo (et al., 2013).

Graphic 4  
Spot Actimel Group 2

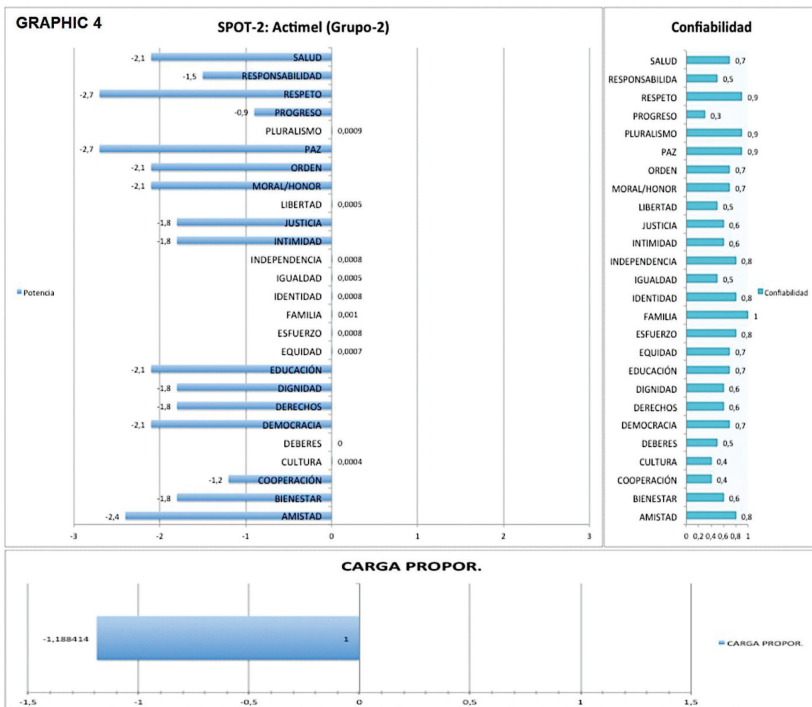

Source: Rodríguez-Bravo (et al., 2013).

Graphic 5  
Spot Niños Group 1

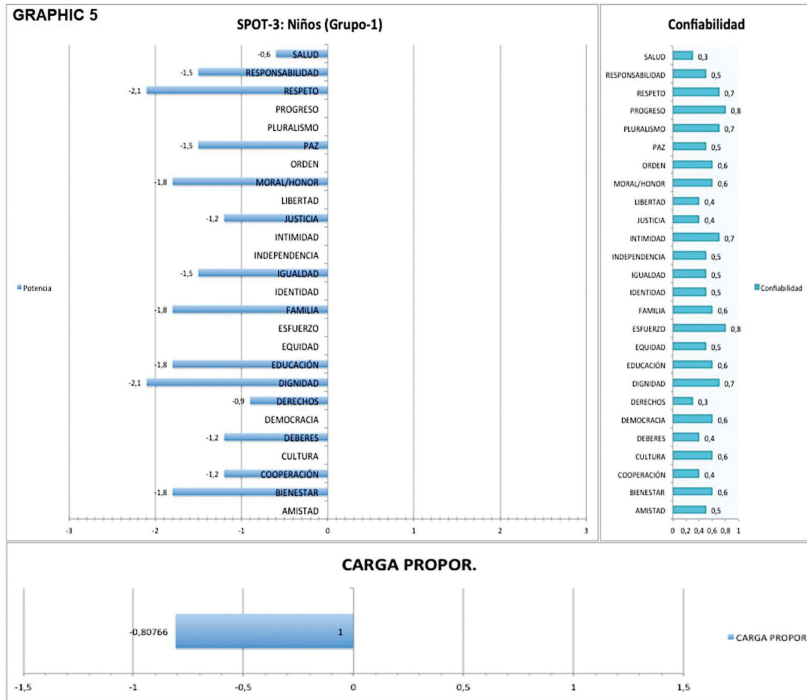

Source: Rodríguez-Bravo (et al., 2013).

Graphic 6  
Spot Niños Group 2

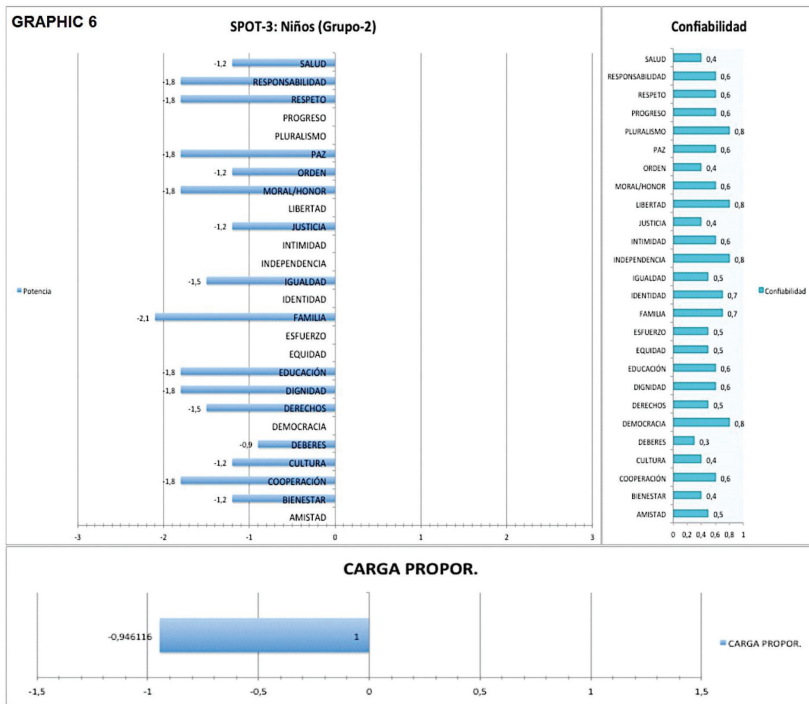

Source: Rodríguez-Bravo (et al., 2013).

Graphic 7  
Spot Pingüinos Group 1

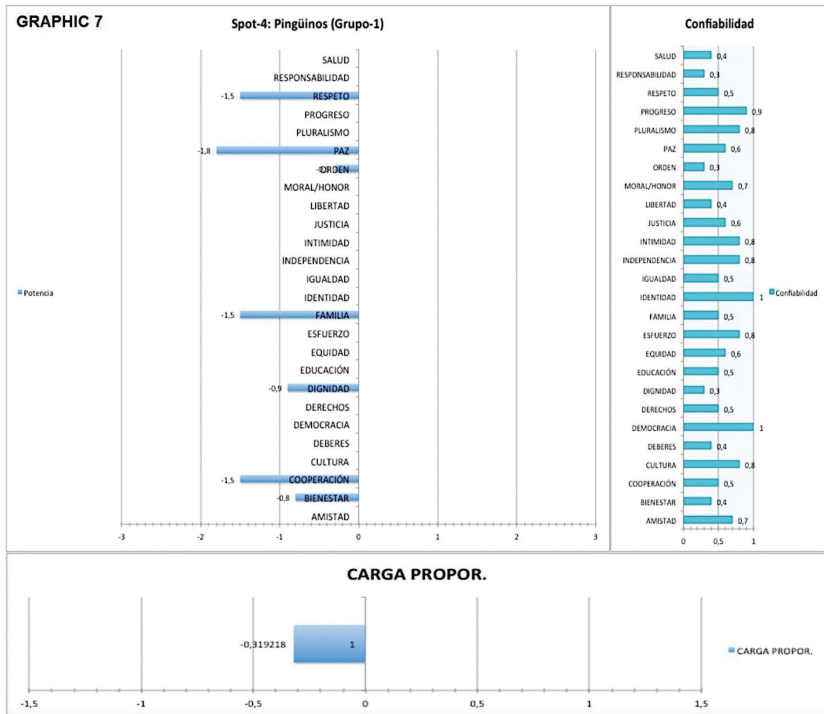

Source: Rodríguez-Bravo (et al., 2013).

Graphic 8  
Spot Pingüinos Group 2

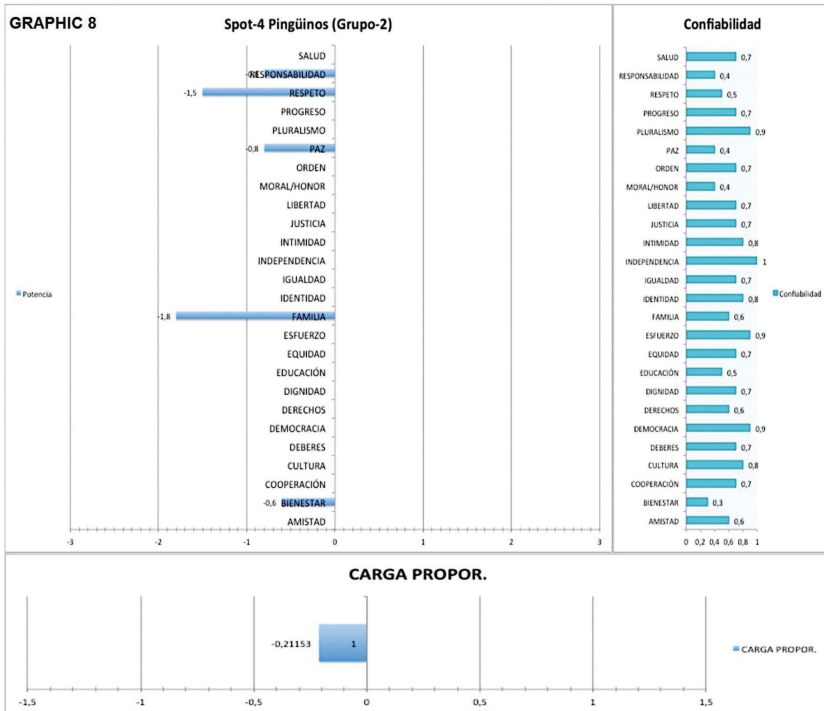

Source: Rodríguez-Bravo (et al., 2013).

These eight previous graphics are organized in pairs of experts. Each pair shows the results of the assessment at the same spot with values, for both groups of experts participating in the test. The distribution of the different *power of value* (*potencia de valor*) is shown in the *upper left of each chart*. This parameter expresses the strength of each specific value in the content of the spot analyzed. The bars that represent the power graphically can be to the left or to the right of the central axis.

When the *power of value* is *positive* (between 0 and 3), the bar is placed to the right of the graphic (see **Graphic 1**). On the other hand, when the *power of value* obtained is *negative* (between

0 and -3) the bar appears on the *left* (see **Graphic 6**). Thus, just by giving a general glance, for example at **Graphic 1**, we can immediately deduce that the content of the *Monos* spot has been perceived as quite favorable to the values assessed, with the only exception of the value *Dignidad* (*Dignity*). By other side, when looking at the **Graphic 6**, is evident that the content of the spot judged is strongly contrary to the values that we are evaluating.

In the upper right area of each graphics is located the *Reliability* table indicating the proportional part of evaluating subjects that are agree to give exactly the same answer for each specific value (Range: 0 to 1, a 0 would indicate that no subject coincides and a 1 that all subjects coincide).

Finally, at the bottom of each chart, is showed the *global load of value*. This parameter expresses in a single figure (graphically, in a single bar), the global perception of favorable and unfavorable contents of the values that the spot has transmitted. The range of the *global load of value* is between -3 and 3. Thus, for example, a result of -3 would express that the contents of the spot with the value under analysis is perceived as *radically contrary* to the whole set of inventory values, without any exception.

As it was explained (see **Table 3.2**), in the first stage of protocol validation, the objectives were: **a**. The checking of coherence among the groups of experts participating in the experience and **b**. The detection of problems in the procedure and the correction of failures.

### 3.2.9. Power of value: graphic analysis

The methodological approach of this first stage of validation, is strictly qualitative and is based on the location of visual evidences favorable or unfavorable to the hypotheses. These evidences have been obtained by systematically comparing the data and the graphics generated by the tests.

A first general comparative review of the eight power of value graphics, shows very clearly the similarity between the visual

contours of the bar graphics that correspond to the same spot, but to a different group of subjects. And the opposite is true, if we compare the visual contours of bar graphics corresponding to different spots, whatever the group of subjects chosen.

This first evidence would therefore be favorable to our two working hypotheses in all the analyzed cases.

### 3.2.10. Global load of value analysis

Let us now take the results of *Global load of value* for comparison, also, with respect to the same place and groups of experts; and regarding different spots we have the **Table 3.6**.

Table 3.6  
Global load of value results

Spot	Group	Global load of value
Monos	1	0.349
	2	0.249
Actimel	1	-0.507
	2	-1.188
Niños	1	-0.807
	2	-0.946
Pingüinos	1	-0.319
	2	-0.211

Source: Rodríguez-Bravo (*et al.*, 2013).

When we are studying this parameter, it is evident, the similarity of the data between the two groups of experts who evaluated the values of the spots: *Monos*, *Niños* and *Pingüinos*, but we can not affirm the same for *Actimel* spot. It is clear, also, the difference between the *global load of values* each other, if we do not consider the *Actimel* spot. Hence, we can affirm, that the results of six of the eight tests are favorable to our hypothesis (See **Table 3.4**)



### 3.2.11. Dominant value analysis

Finally, a more detailed analysis was applied, in order to verify if the hypotheses are fulfilled for the values with greater presence in the content of the spots. Hence, from the eight test results were selected two values with the highest power of value (perceived as more intense presence) and besides, have a reliability  $\geq 0.5$  (half or more of the evaluating subjects have exactly matched their response to the test). See **Table 3.7**.

*Table 3.7*  
Dominant values results

Spot	Group	Values	Power of value	Reliability
<i>Monos</i>	1	1º. Amistad (Friendship)	2.7	0.9
		2º. Cooperación (Cooperation)	2.1	0.7
	2	1º. Amistad (Friendship)	2.7	0.9
		2º. Cooperación (Cooperation)	1.8	0.6
<i>Actimel</i>	1	1º. Respeto (Respect)	-2.7	0.9
		2º. Paz (Peace)	-1.8	0.6
	2	1º. Respeto (Respect)	-2.7	0.9
		2º. Paz (Peace)	-2.7	0.9
<i>Niños</i>	1	1º. Respeto (Respect)	-2.1	0.7
		1º. Dignidad (Dignity)	-2.1	0.7
		2º. Familia (Family)	-1.8	0.6
	2	1º. Familia (Family)	-2.1	0.7
		2º. Respeto (Respect)	-1.8	0.6
		2º. Dignidad (Dignity)	-1.8	0.6
<i>Pingüinos</i>	1	1º. Paz (Peace)	-1.8	0.6
		2º. Respeto (Respect)	-1.5	0.5
		2º. Familia (Family)	-1.5	0.5
		2º. Cooperación (Cooperation)	-1.5	0.5
	2	1º. Familia (Family)	-1.8	0.6
		2º. Respeto (Respect)	-1.5	0.5

Source: Rodríguez-Bravo (*et al.*, 2013).

This table shows again, a high similarity and coherence between the responses of both groups of evaluating subjects that assessed the content in values of a same spot. The pair of values perceived with the highest *power of value* by both groups of experts, agrees in the four spots analyzed, with the only exception of the value Paz (Peace) for the spot Pingüinos (Penguins); instead of appearing in the second place in the results of group 2 of experts, it appears in third place, with a power of value of -0.8 and a reliability of 0.4.

On the other hand, it is possible to verify that the comparisons among different spots, what are the pair of values perceived with highest power of value, and for consequence, the differences are evident again.

Consequently, we can affirm that the results of the tests regarding to the dominant values in the content of the spots are, according to our hypotheses. See **Table 3.4**.

### *3.2.12. Discussion groups development*

Immediately after being exposed to the test, each group of experts must participate in a discussion group aimed to evaluate their experience with the protocol, and its problems and virtues. The central objective is the detection of eventual problems (interpretation and comprehension of values) in the test procedure and, hence, it must be solved.

The proposal that was made to the participants of the discussion group was what they had to expose and defend in their own perception of the values evaluated in the spots. Its objective was to convince the rest of those present; or, to reach an agreement on how each value should be evaluated. Se **Table 3.8**.

Table 3.8  
Discussion groups procedure

Step	Description
1	Before starting the discussion on each spot, it was screened again.
2	The facilitator of the group asks the participants to explain their answers and justify them.
3	The discussion begins with the ultimate goal of convincing or reaching a consensus.
4	The facilitator intervenes to clarify positions, find points of encounter, integrate new postures, etc.
5	If consensus is not possible, a vote is taken on: the presence or not of the value, the positive or negative inclination, and the intensity of the value.
6	The discussion between the subjects of the group can be recorded in audio and is followed with annotations by the researcher who directs the group and by two observers.

Source: Rodríguez-Bravo (*et al.*, 2013).

### 3.2.13. Discussion groups results

The first observation of the results of the discussion group was that the evaluating subjects had a clear and logical perception regarding the overall functioning of the test and an excellent understanding of the whole **EVA protocol**.

However, an interesting phenomenon of *over-analysis* was highlighted. While a group of discussion agreed quickly and without problems the answer on certain values, the other group was engaged in great conceptual discussions about them. By relating this phenomenon with the results of the test, we see that the big discussions, since we are in a group or another, we are looking for the most important results. In other words, *when evaluating subjects respond in a more intuitive and automatic way, the global load of values tends to decrease (the detected values are coincident), and the coherence between the two groups increased. On the contrary, when the over-analysis occurs, the global load of values tends to increase (the subjects detect many values) but the coherence between the detected groups (the detected values are not coincident).* This

phenomenon explains very well the little coherence observed among the groups of experts for the case of the spot *Actimel*.

Finally, the discussion groups also revealed the following problems in the procedure:

1. Confusion between the values *justicia* (*justice*) and *equidad* (*equity*).
2. Difficulty in deciding how the *cultura* (*culture*) value should be interpreted.
3. Confusion between the possibility to indicate the absence of a value: not ticking a value in the scale, or ticking the central of the scale.
4. The need to introduce into the test, sociodemographic variables that help its interpretation.

### *3.3. Validating the EVA protocol to the value-based innovation model*

We have reviewed how the **EVA protocol** works and its ability to measure the transmission of values and how this powerful tool can be incorporated into our conceptual model proposal to make decision, monitoring and reviewing (modify, add, delete) the management of securities in a corporation (see section 3.1), allows us to measure and compare the load of values transmitted in different media of communications, and assessed by the same group of people. The **EVA protocol** can also be applied in the opposite direction: comparing and measuring the model of values received by two or more different groups of people exposed to the same message-pattern (Mas-Manchón, Rodríguez-Bravo et al., 2015, 2016).

Rodríguez Bravo and his research team have experimentally verified two groups of young people between 18 and 25 years old with different values education. When they were exposed to 7 food advertising spots, they identified loads of very different values. The loads of perceived values did not differ in the intra-group analysis, but they were significantly different in the inter-group analysis.

The first group of the experiment (66 young people) were patients of the ITA (Institute of Eating Behavior Disorders of Barcelona) who had been diagnosed as subjects with eating disorders (EBD. Eating Behavior Disorders) and underwent reeducation of their values on food. The second group were 73 students from the Autonomous University of Barcelona without this type of disorders (without diagnosed disorders). The group of subjects with EBD, who had received re-education of their values, showed much more refractory to the advertising influence and perceived, in general, a load of values rather smaller and different than the subjects without diagnosed disorders. The results of this experiment indicate that **EVA protocol** can be applied to measure whether different groups of people in an organization or a company (board of directors, marketing and sales department, engineering department, etc.) having different models of values. By exposing the different groups of management responsible for the same communication, for example to several corporate videos of the company, and asking them to evaluate them using the **EVA protocol**, we will be able to find out if there is inconsistency between them, to identify with precision in which specific values they are the differences and measure the strength they have. This new knowledge will allow the company to initiate a dynamic of agreements and sharing of a new value model that is much more solid, coherent and aimed at specific objectives (for example, promoting innovation activities).

This type of measurement of the differences and similarities between value models can be made, also, by comparing the internal audiences of a corporation (partners, management members, employees) with external audiences (customers, consumers, users, etc.). In summary, the incorporation of **EVA protocol** in the Value-Based-Innovation Model would make available to any company or corporation the possibility of monitoring and making decisions about the control (change, extension, complementation, deletion) and the addressing of its models of values towards very specific objectives, thus increasing their effectiveness and efficiency.

## Chapter 4

# Starting a case of study

This research is aimed to determine the main values-based innovation able to focus the human resources in the organizations, to encourage the innovation with higher impact and accurate results for competitiveness, based on successful worldwide firms to be applied in Mexico and Spain (as a benchmarking, the most innovators firms at worldwide, no matter what industries or sectors are being). The mentioned above, is especially important in first instance to the firms specialized in software design, located in the Guadalajara Software Design Center (**GSDC**), México. This research is based on literature review to analyze and determine a conceptual model that classifies the influence of the main values-based innovation in the organization. We made an analysis of the values most valued in the 15 main successful firms at: Worldwide, Spain, México (5 each one) and the **GSDC**. Therefore, we determined the groups of the main values-based innovation, where were gathered and represented the successful firms, located in the **GSDC**. In order to feature, each one of the final values-based innovation there were involved 3 experts in values-based innovation and organization architecture during the period: Aug-Sep-2017, using Panel Delphi Focus Group and Analytic Hierarchy Process (**AHP**). The final results, were: *82 different values-based innovation* (including 4 added as suggestions of experts vision), distributed in a conceptual model in Innovation Level, with 3 main subareas, called: Normative Innovation (Production); Business Model Innovation (Consump-

tion); Process/Product-Service Innovation (Differentiation from others). These results are the first insights in Mexico, to be assessed in a complementary study in Spain to obtain a value-based innovation generalized model in a subsequent study.

*Keywords: Values-Based Innovation; Organization; Competitiveness, Mexico; Spain.*

JEL Classification: M10, O30.

### **a. Introduction**

According OECD (2005), innovation is: *the implementation of a new or significantly improved product (good or service), or process, a new marketing method, or a new organizational method in business practices, workplace organization or external relations (par. 146)...* Therefore, *Innovation aims at improving a firm's performance by gaining a competitive advantage (par.101e)...* but, how is related with the values in an organization, to be fostered? In nowadays values are understood to be one of the foundations of successful companies. In fact, a quit simple mission statement, vision and their set of values, can take weeks, months or even years, to design involving multiple parties participating in the process (Mitland, 2015), being critical in such developed sectors such as the software design. To achieve our proposal to determine which are the values to foster innovation (values-based innovation) in the organizations to be more competitive, this work is divided into the explanation of: a) Problem, hypotheses and rationale of the study; b) Methodology based on two visions: the looking for websites and the experts to obtain several values-based innovation and then identify the group where they belonging, according a proposal of value-based innovation model; c) Literature review d) Analysis e) Results; f) Conclusions and future studies.

### ***b. Problem, hypotheses and rationale of the study***

Our problem is described in a research question: *Which are the values to foster innovation (values-based innovation) in the organizations to be more competitive?* If we got this, we will be capable to focus the human resources in the organizations, to encourage the innovation with higher impact and accurate results. The mentioned above, is especially important to ten firms specialized in software design, located in the Guadalajara Software Design Center **GSDC**), México.

Hence, we proposed the following specific questions (SQ):

**SQ1:** *What is the conceptual model that classifies the influence of the main values-based innovation in the organization?*

**SQ2:** *What are the main values to foster innovation (values-based innovation), most valued in the 15 main successful firms (5, each one) in the Worldwide, Spain and México?;*

**SQ3:** *What are the main values to foster innovation (values-based innovation), most valued in the 10 main successful firms located in the **GSDC**?;*

Based on the 25 successful firms, mentioned above:

**SQ4:** *What are the main groups of the values-based innovation identified of those successful firms and the expert vision?*

**SQ5:** *What are the recommended values-based innovation model to the **GSDC**?*

### ***c. Methodology***

To solve the specific questions mentioned above, we did a serial of activities gathered in features and finally summarized, briefly as technical data. See **Table 4.1**.



*Table 4.1*  
Technical research data

Features	Survey
-Literature Review	<p>To analyze and determine:</p> <ol style="list-style-type: none"> <li>1. A conceptual model that classifies the influence of the main values-based innovation in the organization.</li> <li>2. The main values to foster innovation (values-based innovation), most valued in the 15 main successful firms (5, each one) in the Worldwide, Spain and México. We made a survey during Aug-Sep-2017 searching the firms websites in order to capture their corporate values. There were cases we found values stated explicitly as a list of individual nouns and verbs. In others they were expressed in more narrative form, sometimes as part of a declaration which also encompassed vision, mission and purpose making hard the definition in a first glance. Therefore, we allowed ourselves certain degree of interpretation. For example, <i>Team</i> was described as a value by one business; we interpreted this as Teamwork as it can be more accurately described as a value.</li> <li>3. The main values to foster innovation (values-based innovation), most valued in the 10 main successful firms, located in the GSDC.</li> </ol>
-Website research of corporate values and expert vision for searching and featuring the main values-based innovation, according Panel Delphi Focus Group and Analytic Hierarchy Process (AHP)	<ol style="list-style-type: none"> <li>1. The values-based innovation were translated in features based on 3 experts in values-based innovation and organization architecture, using Panel Delphi Focus Group and AHP, being form GSDC : 1 manager software design, 1 consultant and 1 CEO.</li> <li>2. The features were determined during the period: Aug-Sep-2017</li> </ol>
-Final recommendation of values-based innovation for firms of GSDC	<p>A final list ordered by importance, of values-based innovation recommended for the 3 experts mentioned above, to the GSDC</p>

Source: own.

#### ***d. Literature review***

In this section, we established the meanings of the values-based innovation, their importance, their senses, how they do help to the innovation; potential problems, desirable features, and its evaluation.

The values are the source to incorporate the vision/mission, the corporate values and customer values basically into the different management levels of the firm, leading to different forms of our conceptual model proposal. See **Figure 3.1**.

There are some possible problems when the organization is introducing or managing values-based innovation (AUSG,2017), such as:

- *Values-based innovation vs Process*. If processes do not support the values-based innovation, may be seen as rhetoric rather than aspirational.
- *Values-based innovation vs Behaviour*. If there is a contrast between the stated norms of the organization and the observed behaviour, many problems could be generated. If values-based innovation are not supported and realized in the operations of the organization, then the values may act to undermine support for innovation rather than encourage it.
- *Values-based innovation vs Move Fast*. It is a common pitfall, when people is expecting that the values-based innovation be embedded into an organization as soon as it is written down. The Implementing will take time and patience so do not be discouraged if you do not see instant results. Adoption of values requires people to come on board and this will take time and require guidance from innovation champions.

### e. Analysis

Any organization must show the exact nature of its values-based innovation and will need to reflect any existing broader values. The values-based innovation may be placed as the higher level values or be an explicit sub-set to reflect a particular emphasis on innovation. The values-based innovation should reflect the environment and context of the organization and embody what is believed and hoped for innovation. If the values are introduced to help change or create a new approach to innovation, then this should be backed by strategies to help staff make the transition. (AUSG, 2017; Breuer, H. and Lüdeke-Freund (2015).

If we review the websites of the most important firms that all of them are distinguished for highest innovations levels, we can determine the core values. For instance, as a sample, we detected the values-based innovation, that are boosting **25 main Firms** at: Worldwide, Spain, Mexico. See **Table 4.3**

*Table 4.3*  
Firms, core value definitions and main values

The Worldwide Successful Firms in 2017 (El Economista, 2017a)		
No.	Firms	Main Values
1	Apple	"...Greatness ( <i>GRT</i> ); Simplicity ( <i>SIM</i> ); Technology ( <i>TEC</i> ); Market Contribution ( <i>MKC</i> ); Focus on Customer ( <i>CUS</i> ); Collaboration ( <i>COL</i> ); Excellence ( <i>EXC</i> )
2	Alphabet (Google)	"...Integrity ( <i>INT</i> ); Usefulness ( <i>USF</i> ) Privacy, Security, and Freedom of Expression ( <i>PSF</i> ); Responsiveness ( <i>RES</i> ); Take Action ( <i>ACT</i> )..."
3	Microsoft	"...Innovation ( <i>INN</i> ); Diversity & Inclusion ( <i>D&amp;I</i> ); Corporate Social Responsibility ( <i>CSR</i> ); Philanthropies ( <i>PHI</i> ); Environment ( <i>ENV</i> ); Trustworthy Computing ( <i>TSW</i> )..."

4	Amazon	“...Customer Obsession ( <i>CUS</i> ); Ownership ( <i>OWN</i> ); Invent & Simplify ( <i>I&amp;S</i> ); Leaders are Right a Lot ( <i>LRL</i> ); Frugality ( <i>FRG</i> ); Hire & Develop the Best ( <i>H&amp;D</i> ); Earn Trust ( <i>TRS</i> ); insist on the Highest Standards ( <i>HST</i> ); Bias for Action ( <i>ACT</i> ); Learn & Be curious ( <i>L&amp;C</i> ); Have Backbone. Disagree ( <i>RDS</i> ) and Commit ( <i>COM</i> ); Dive Deep ( <i>DDP</i> ); Think Big ( <i>TBG</i> ); Deliver Results with Quality ( <i>RSO &amp; QTY</i> )...”
5	Facebook	“...Focus on Impact ( <i>CUS</i> ); Move Fast ( <i>MVF</i> ); Be Bold ( <i>BBD</i> ); Build Social Value ( <i>BSV</i> )...”

**The Spain’s Successful Firms in 2017 (BrandFinance, 2017)**

No	Firms	Main Values
6	Santander	“...Dynamism ( <i>DYN</i> ); Strength ( <i>STR</i> ); Leadership ( <i>LDS</i> ); Innovation ( <i>INN</i> ); Quality Service and Customer Satisfaction ( <i>QTY &amp; CUS</i> ); Professional Ethics and Sustainability ( <i>ETH &amp; SUS</i> )...”
7	Zara	“...Professional ethics ( <i>ETH</i> ); Commitment ( <i>COM</i> ); Confidence ( <i>TRS</i> ); Loyalty ( <i>LTY</i> ); Creativity ( <i>CRY</i> )...”
8	Movistar	“...Trusted ( <i>TRS</i> ); Bold ( <i>BBD</i> ); Open ( <i>OPN</i> )...”
9	BBVA	“...Integrity ( <i>INT</i> ); Prudence ( <i>PRD</i> ); Transparency ( <i>TRP</i> )...”
10	Iberdrola	“...Creation of sustainable value ( <i>SUS</i> ); Ethical principles ( <i>ETH</i> ); Good corporate governance ( <i>GOV</i> ) and transparency ( <i>TRP</i> ); Development of our workforce ( <i>WOK</i> ); Social commitment ( <i>SCO</i> ); Sense of belonging ( <i>SBG</i> ); Safety and reliability ( <i>SEC &amp; REL</i> ); Quality ( <i>QTY</i> ); Innovation ( <i>INN</i> ); Respect for the environment ( <i>ENV</i> ); Customer focus ( <i>CUS</i> ); Institutional loyalty ( <i>LTY</i> )...”

**The Mexico’s Successful Firms in 2017 (El Economista, 2017b)**

No	Firms	Main values
11	Corona	“...Be honest ( <i>INT</i> ); Report and make yourself felt ( <i>RPT</i> ); Rely on ( <i>REL</i> ); Commitment ( <i>COM</i> ); Act with austerity ( <i>AUS</i> ); Fulfill your commitments and honor the word pawned ( <i>HON</i> ); Be transparent and require transparency ( <i>TRP</i> ); Declare your independence and commitment to ethics ( <i>ETH</i> ); Respect the law ( <i>REP</i> ); Be accurate and truthful ( <i>ACC</i> ); Report on ( <i>RPT</i> ); Management conflict ( <i>MCO</i> ); Respect the dissent ( <i>RDS</i> ) ...”
12	Cemex	“...Ensuring Security ( <i>SEC</i> ); Focus on Customer by listening to our customers ( <i>CUS</i> ); Seek Excellence ( <i>EXC</i> ); Working as one CEMEX ( <i>Greatness:GRT</i> ); Act with integrity ( <i>INT</i> ) ...”
13	Oxxo (FEMCO)	“..Central Values ( <i>FEMCO</i> ); Integrity ( <i>INT</i> ); Respect ( <i>REP</i> ); Simplicity ( <i>SIM</i> ); Teamwork ( <i>TWK</i> ); Soberness ( <i>SOB</i> )..” Business Values ( <i>FEMCO</i> ): Service Passion ( <i>SAT</i> ); Renovation ( <i>REN</i> ); Oriented to the Job ( <i>ORJ</i> ); Leadership ( <i>LDS</i> )

14	Telmex	“...Work ( <b>WOK</b> ); Growing ( <b>GRO</b> ); Austerity ( <b>AUS</b> ); Commitment ( <b>COM</b> ); Social Responsibility ( <b>CSR</b> ) ...”
15	Bimbo	“...The persons ( <b>PER</b> ); The community ( <b>TCO</b> ); We get results ( <b>RES</b> ); We compete and win ( <b>C&amp;W</b> ); We are effective operators ( <b>OPE</b> ); We act with integrity ( <b>INT</b> ); We transcend and stay in time ( )...”

**The Guadalajara’s Mexico Successful Software Development Firms at GSDC**

No	Firms	Main Values
16	GSDC Guadalajara	“ Integrity ( <b>INT</b> ); Service professionalization ( <b>PRF</b> ); Action with responsibility ( <b>ACT &amp; RES</b> ); Sustentability ( <b>SUS</b> )...”
17	Algartech	“...Sustainability ( <b>SUS</b> ); Innovation ( <b>INN</b> )...”
18	Amdocs	“...Teamwork ( <b>TWK</b> ); play to win ( <b>C&amp;W</b> ); Commitment ( <b>COM</b> ); Respect ( <b>RES</b> ); Deliver value to our customers ( <b>CUS</b> ); We dare to change ( <b>CHG</b> ); Passion to lead ( <b>LDS</b> ); We strive for excellence ( <b>EXC</b> ); Professionalism ( <b>PRF</b> )..”
19	Avantec	“...Experts ( <b>EXP</b> ); Committed ( <b>COM</b> ); Passionate Avant-garde ( <b>Greatness. GRT</b> ) Reliable Service attitude ( <b>REL &amp; SAT</b> )
20	Bitam	“...Service attitude ( <b>SAT</b> ); Loyalty ( <b>LTY</b> ); Honesty ( <b>INT</b> ) Innovation ( <b>INN</b> ); Passion for what we do ( <b>Greatness. GRT</b> ); Harmonic and Productive Environment (Place to Work. <b>PTW</b> )..”
21	Bosch	“...Orientation towards the future and the result ( <b>FUT &amp; RSO</b> ); Responsibility and sustainability ( <b>RES &amp; SUS</b> ); Initiative and Coherence ( <b>INI &amp; COH</b> ); Transparency and Trust ( <b>TRP &amp; TRS</b> ); Honesty ( <b>INT</b> ); Reliability, credibility and legality ( <b>REL &amp; TRS &amp; LEG</b> ); Diversity ( <b>D&amp;I</b> )...”
22	Ecodex	“...Responsibility ( <b>RES</b> ). Commitment ( <b>COM</b> ). Loyalty ( <b>LTY</b> ). Punctuality ( <b>PUN</b> )...”.
23	Evolutel	“...Positive Attitude ( <b>SAT</b> ); Loyalty ( <b>LTY</b> ); Excellence in achieving objectives ( <b>EXC</b> ); Professionalism ( <b>PRF</b> ); Honesty ( <b>INT</b> ); Innovation ( <b>INN</b> )...”
24	Nasoft	“...Excellence ( <b>EXC</b> ); Integrity ( <b>INT</b> ); Commitment( <b>COM</b> ); Innovation ( <b>INN</b> ); Passion ( <b>SAT</b> )..”
25	Qualtop	“... Teamwork ( <b>TWK</b> ); Experience ( <b>EXP</b> ); Innovation ( <b>INN</b> ); Agility ( <b>AGY</b> )...”

Source: Internet Portals, El Economista (2017a,b) and Brandfinance (2017) with own adaptation.

Thus, we obtained from the most successful firms **78 main values**. To understand the relevance of each one, it was possible

to determine the frequency of the presence of those values as shown in **Table 4.4**.

*Table 4.4*  
Frequency of main values

Freq.	Q	Main values
1	44	ACC; AGY; BSV; CHG; COH; COL; CRY; DDP; DYN; FRG; FUT; GOV; GRO; H&D; HON; HST; I&S; INI; L&C; LEG; LRL; MCO; MKC; MVF; OPE; OPN; ORJ; OWN; PER; PHI; PRD; PSF; PTW; PUN; SBG; SCO; SOB; STR; T&S; TBG; TCO; TEC; TSW; USF
2	14	AUS; BBD; C&W; CSR; D&I; ENV; EXP; RDS; REN; REP; RPT; RSO; SEC; WOK
3	5	ACT; PRF; QTY; SIM; LDS
4	6	ETH; EXC; GRT; REL; TRP ; TWK
5	4	LTY; SAT; SUS; TRS
6	1	RES
7	2	CUS; INN
9	1	COM
10	1	INT
Total	78	

Note: **Freq.** Frequency; **Q**, Quantity; **ACC**. Accurate; **ACT**. Action; **AGY**. Agility; **AUS**. Austerity; **BBD**. Be Bold; **BSV**. Build Social Value; **CHG**. Change; **COH**. Coherence; **COL**. Collaboration; **COM**. Commitment; **CRY**. Creativity; **CUS**. Customer; **CSR**. Corporate Social Responsibility; **C&W**. Compete & Win; **ETH**. Ethics.; **ENV**. Environment; **EXC**. Excellence; **EXP**. Experience; **D&I**. Diversity & Inclusion; **DDP**. Dive Deep; **DYN**. Dynamism; **FRG**. Frugality; **FUT**. Future Vision. **GOV**. Governance; **GRO**. Growing; **GRT**.Greatness; **H&D**. Hire & Develop the Best; **HON**. Honor; **HST**. Highest Standards; **I&S**. Invent & Simplify; **INI**. Initiative; **INN**. Innovation; **INT**. Integrity; **L&C**. Learn & Be Curious; **LDS**. Leadership; **LEG**. Legality; **LRL**. Leaders are Right a Lot; **LTY**. Loyalty; **MCO**. Management Conflict ; **MKC**. Market Contribution ; **MVF**. Move Fast; **OPE**. Effective Operators; **OPN**. Open ; **ORJ**. Oriented to the Job; **OWN**. Ownership; **PER**. Persons; **PHI**. Philanthropies; **PRD**. Prudence; **PRF**. Professionalism; **PSF**. Privacy, Security, and Freedom of Expression; **PTW**. Place to Work ; **PUN**. Punctuality; **QTY**. Quality; **REL**. Rely On; **REN**. Renovation; **REP**. Respect; **RES**. Respect; **RDS**. Respect the dissent; **RPT**. Report on; **RSO**. Results Oriented; **SAT**. Service Attitude; **SBG**. Sense of Belonging; **SCO**. Social Commitment; **SEC**. Security ; **SIM**. Simpleness; **SOB**. Soberness; **STR**. Strength; **SUS**. Sustainability; **T&S**;. Transcend and Stay in Time; **TBG**. Think Big; **TCO**. The Community; **TEC**.

Technology; **TRS**. Trust. **TRP**. Transparency; **TSW**. Trustworthy Computing ; **TWK**. Teamwork; **USF**. Usefulness; **WOK**. Work.  
Source: own.

As a complementary study, is necessary to do an analysis to determine the levels of sense and intensity for each one of these values-based innovation obtained. This study would be feasible, applying the evaluation of values (**EVA**) protocol designed by **LAICOM** (Laboratory of Instrumental Analysis of the Communication; Universidad Autónoma de Barcelona, Spain). With such data and results, it would be replicate the entire study to obtain the main values-based innovation (Panel Delphi Focus Group and **AHP**) and their sense and intensity (**EVA protocol**) for successful firms of software design (just like in Guadalajara México), but in Barcelona, Spain. Obtaining the mentioned above, would allow us to establish divergence or convergence around the values-based innovation in these two countries, in the same sector (software design) seemingly similar in culture and idiom.

## ***f. Results***

As a result of the literature review and the website research, it was made the featuring of the main values-based innovation according Delphi Focus Group and Analytic Hierarchy Process (**AHP**) with 3 experts in values-based innovation and organization architecture, from **GSDC**, as: 1 manager software design, 1 consultant and 1 CEO. The survey panel was made during the period: Aug-Sep-2017. The stages were 3, according the proposed conceptual values-based innovation model (**Figure 3.1**), called: Normative Innovation (see **Table 4.5**); Model Business innovation (see **Table 4.6**) and Process/Product-Service Innovation from others-(see **Table 4.7**)

Table 4.5

Focus group by Delphi panel and AHP to determine the main values-based innovation for normative innovation (suggested by Experts Vision)

	Order Suggested for expert vision	Main Values-Based innovation	Factor as Website Research		Factor as Expert Vision	%Difference >[2.0] (Website Research-Expert vision)	Predominant Vision
			Freq.	%	AHP weighted as Expert Vision (%)		
	1	ETH	4	4.4	4.2	0.2	Similar
	2	INT	10	11.1	3.7	<b>7.4</b>	<b>Website Research</b>
	3	EXC	4	4.4	7.9	<b>-3.5</b>	<b>Expert</b>
	4	GRT	4	4.4	3.2	1.2	Similar
	5	LDS	3	3.3	6	<b>-2.7</b>	<b>Expert</b>
	6	AUS	2	2.2	6.9	<b>-4.7</b>	<b>Expert</b>
	7	CSR	2	2.2	2.2	0.0	Similar
	8	ENV	2	2.2	4.5	<b>-2.3</b>	<b>Expert</b>
	9	SUS	5	5.6	2.8	<b>2.8</b>	<b>Website Research</b>
	10	RES	6	6.7	2.2	<b>4.5</b>	<b>Website Research</b>
	11	COM	9	10.0	2.9	<b>7.1</b>	<b>Website Research</b>
	12	RDS	2	2.2	1.1	1.1	Similar
	13	REP	2	2.2	2.8	-0.6	Similar
	14	PRF	3	3.3	3.9	-0.6	Similar
	15	CHG	1	1.1	2.2	-1.1	Similar
	16	FUT	1	1.1	0.9	0.2	Similar
	17	HON	1	1.1	0.1	1.0	Similar
	18	LEG	1	1.1	2.9	-1.8	Similar
	19	PHI	1	1.1	0.1	1.0	Similar
	20	PER	1	1.1	3.2	<b>-2.1</b>	<b>Expert</b>
	21	PSF	1	1.1	3.3	<b>-2.2</b>	<b>Expert</b>
	22	PTW	1	1.1	3.8	<b>-2.7</b>	<b>Expert</b>
	23	PUN	1	1.1	2.2	-1.1	Similar
	24	SBG	1	1.1	1.2	-0.1	Similar
	25	SOB	1	1.1	3.5	<b>-2.4</b>	<b>Expert</b>
	26	T&S	1	1.1	3.2	<b>-2.1</b>	<b>Expert</b>
	27	D&I	2	2.2	0.8	1.4	Similar
	28	QTY	3	3.3	3.9	-0.6	Similar



	Order Suggested for expert vision	Main Values-Based innovation	Factor as Website Research		Factor as Expert Vision	%Difference >[2.0] (Website Research-Expert vision)	Predominant Vision
			Freq.	%	AHP weighted as Expert Vision (%)		
Alternatives	29	SEC	2	2.2	4.7	-2.5	Expert
	30	REL	4	4.4	3.2	1.2	Similar
	31	TRP	4	4.4	3.9	0.5	Similar
	32	LTY	5	5.6	2.6	3.0	Website Research
Total			88	100	100	-	-

Source: Own.

This table shows the opportunity to be more clear the contribution of values concepts, such as: INT; EXC; LDS; AUS; ENV; SUS; RES; COM; PER; PSF; PTW; SOB; T&S; SEC; LTY with respect the websites firm's and the expert vision.

Table 4.6

Focus group by Delphi panel and AHP to determine the main values-based innovation for business model innovation (suggested by Experts Vision)

	Order Suggested for expert vision	Main Values-Based innovation	Factor as Website Research		Factor as Expert Vision	%Difference >[2.0] (Website Research-Expert vision)	Predominant Vision
			Freq.	%	AHP weighted as Expert Vision (%)		
Alternatives	1	PEF	0	0	0	0	Experts Suggestion
	2	INN	7	21.2	13.5	7.7	Website Research
	3	REP	2	6.1	7.2	-1.1	Similar
	4	TEC	1	3.0	6.2	-3.2	Expert
	5	SCO	1	3.0	5	-2.0	Similar
	6	OWN	1	3.0	3.2	-0.2	Similar

	Order Suggested for expert vision	Main Values-Based innovation	Factor as Website Research		Factor as Expert Vision	%Difference > [2.0] (Website Research-Expert vision)	Predominant Vision	
			Freq.	%	AHP weighted as Expert Vision (%)			
Alternatives	7	OPN	1	3.0	3.1	-0.1	Similar	
	8	MVF	1	3.0	4.2	-1.2	Similar	
	9	MKC	1	3.0	4	-1.0	Similar	
	10	MCO	1	3.0	4.9	-1.9	Similar	
	11	LRL	1	3.0	1.2	1.8	Similar	
	12	L&C	1	3.0	3.6	-0.6	Similar	
	13	INI	1	3.0	1.2	1.8	Similar	
	14	I&S	1	3.0	3.6	-0.6	Similar	
	15	HST	1	3.0	3.2	-0.2	Similar	
	16	H&D	1	3.0	2.8	0.2	Similar	
	17	GRO	1	3.0	3.4	-0.4	Similar	
	18	GOV	1	3.0	1.2	1.8	Similar	
	19	EXP	2	6.1	3.2	<b>2.9</b>	<b>Website Research</b>	
	20	DYN	1	3.0	3.8	-0.8	Similar	
	21	DDP	1	3.0	4.2	-1.2	Similar	
	22	CRY	1	3.0	3.5	-0.5	Similar	
	23	COL	1	3.0	4.2	-1.2	Similar	
	24	COH	1	3.0	3.2	-0.2	Similar	
	25	ACC	1	3.0	4.4	-1.4	Similar	
	26	BSV	1	3.0	2	1.0	Similar	
	Total			<b>33</b>	<b>100</b>	<b>100</b>	-	-

Notes: PEF. Performance.

Source: Own.

This table shows the suggested value-based innovation **PEF** and the opportunity to be more clear the contribution of values concepts, such as: **INN**; **TEC** and **EXP** with respect the websites firm's and the expert vision.

*Table 4.7*  
Focus group by Delphi panel and AHP to determine the main values based innovation for process/product-service innovation (suggested by Experts Vision)

	Order Suggested for expert vision	Main Values-Based innovation	Factor as Website Research		Factor as Expert Vision	% Difference > [2.0] (Website Research-Expert vision)	Predominant Vision
			Freq.	%	AHP weighted as Expert Vision (%)		
Alternatives	1	R&R	0	0	0	0	Experts
	2	EIN	0	0	0	0	Suggestion
	3	NFR	0	0	0	0	
	4	CUS	7	14.9	15.2	-0.3	Similar
	5	TRS	5	10.6	4.5	6.1	<b>Website Research</b>
	6	SAT	5	10.6	8.2	2.4	<b>Website Research</b>
	7	TWK	4	8.5	7.8	0.7	Similar
	8	SIM	3	6.4	7.2	-0.8	Similar
	9	ACT	3	6.4	8.2	-1.8	Similar
	10	WOK	2	4.3	3.9	0.4	Similar
	11	RSO	2	4.3	8.1	-3.8	<b>Experts</b>
	12	REN	2	4.3	2.4	1.9	Similar
	13	C&W	2	4.3	4.2	0.1	Similar
	14	BBD	2	4.3	3.5	0.8	Similar
	15	USF	1	2.1	4.8	-2.7	<b>Experts</b>
	16	TSW	1	2.1	1.9	0.2	Similar
	17	TCO	1	2.1	2.5	-0.4	Similar
	18	TBG	1	2.1	2.3	-0.2	Similar
	19	STR	1	2.1	2.1	0.0	Similar
	20	PRD	1	2.1	2.4	-0.3	Similar
	21	ORJ	1	2.1	1.9	0.2	Similar
	22	OPE	1	2.1	2.1	0.0	Similar
	23	FRG	1	2.1	2.1	0.0	Similar
	24	AGY	1	2.1	4.7	-2.6	<b>Experts</b>
Total			47	100	100	-	<b>100</b>

Notes: R&R. Rewards & Recognition; EPM. Encourage Informal Networks; No Fear to the Risk.

Source: Own.

This table shows the suggested values-based innovation **R&R**; **EPM** and **NFR** and the opportunity to be more clear the contribution of values concepts, such as: **TRS**; **SAT**; **RSO**; **USF**; **AGY** with respect the websites firm's and the expert vision. Hence, the Final values-based innovation recommended is shown in **Figure 4.1**.

### ***g. Conclusions and future studies***

So far, we can affirm:

- a. We solved the research question: *Which are the values to foster innovation (values-based innovation) in the organizations to be more competitive?*, solving:

**SQ1:** *Which is the conceptual model that classifies the influence of the main values-based innovation in the organization?* It is showed in **Figure 3.1**;

**SQ2:** *Which are the main values to foster innovation (values-based innovation), most valued in the 15 main successful firms (5, each one) in the Worldwide, Spain and México?* It is showed in **Table 4.3**;

**SQ3:** *What are the main values to foster innovation (values-based innovation), most valued in the 10 main successful firms located in the GSDC?* It is showed in **Table 4.3**;

Based on the 25 successful firms, mentioned above:

**SQ4:** *What are the main groups of the values-based innovation identified of those successful firms and the expert vision?*

They are showed in **Tables 4.5, 4.6 and 4.7**.

**SQ5:** *What are the recommended values-based innovation model to the GSDC?* It is showed in **Figure 4.1**.

- b. The main contribution of this study is the use of the conceptual model proposed about values-based innovation for **GSDC**, for México where were obtained finally 82 main values-based innovation, classified in the proposed model in: Normative: 32; Business Model innovation: 26 (1 suggested by expert vision); Process/Product-Service Innovation:

Figure 4.1  
The recommended of values-based innovation model to the GSDC

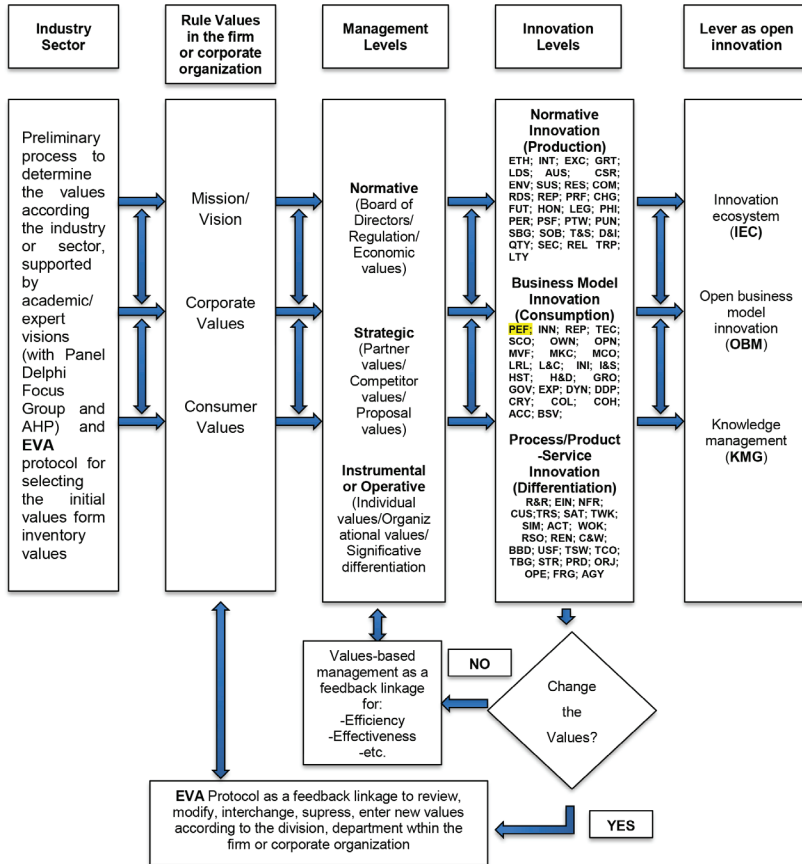

Notes:

- .- Integrative horizontal coherence function;
- ↕ .-Integrative vertical congruence function

Source: Rodríguez Bravo (2013); Mejía-Trejo, 2017 a-b; Breuer, H. and Lüdeke-Freund (2015) with own adaptation

Source: Rodríguez Bravo (*et al.*, 2013); Mejía-Trejo, 2017 a-b; Breuer, H. and Lüdeke-Freund (2015) with own adaptation.

24 (3 suggested by expert vision). As you see, there are opportunities to be more clear the role of the values-based innovation even with no mentioned values in the websites of the current successful firms, such as: Performance (**PEF**); Rewards & Recognition (**R&R**); Encourage informal Networks (**EIN**) and No fear to the Risk (**NFR**).

- c. For future studies, are suggested to do:
- The determining of sense and intensity of each one of these values-based innovation obtained in Guadalajara, México for the software design (**GSDC**) using the evaluation of values (**EVA**) protocol designed in **LAICOM** (Laboratory of Instrumental Analysis of the Communication)
  - With all the data and results obtained in Mexico, to replicate the same study for firms of software design but in Barcelona, Spain.
  - Obtaining the mentioned above, would allow us to establish divergence or convergence around the values-based innovation in these 2 countries, in the same sector (software design) seemingly similar in culture and idiom.

# Conclusions

Values must be integrated within all the levels of a firm or corporate organization and their external environment factors must be considered (for instance: providers, consumers, stakeholders, etc.) providing a priori connections between these systems. This is the main reason of this book, the discussion and disclosure of a model involving the main values-based innovation able to focus the human resources in the organizations, to encourage the innovation with higher impact and accurate results for competitiveness.

Based on a review of literature, we see companies working with values in at least three distinct management levels: normative (for instance: board of directors, the economic values, etc.), strategic (involving different factors such as the partners, competitors, etc.) and instrumental or operative (for instance, the organizational/individual values aligned to a specific vision). Since management view these factors produces relationships, such as normative-production; strategic-consumption and instrumental/operative-remarkable differentiation. By other hand, those management levels are translated as an innovation levels equivalents, for instance: normative (production) as normative innovation, strategic (consumption) as business model innovation and instrumental/operative as process, product-service innovation (differentiation). These two stages: management and innovation are the basis to produce open innovation able to work in both senses: vertical (Integrative vertical congru-

ence function) and horizontal (Integrative horizontal coherence function), being as means as ends of values and by own, interchangeable. For this reason, is necessary to consider two stages of decision:

- One stage is the assessment the key performance indicators of the actual values in the firm or corporate organization, our general conceptual model proposal involves a process based on efficiency and effectiveness supported with value-based management.
- The next one stage, is the review of the actual values in the firm or corporate organization for modifying, interchanging, surpressing entering new ones, our general conceptual model proposal involves **EVA protocol** process. In this step it was offered two empirical and previously implemented studies:

The Mejía-Trejo (2017c) model as a preliminary process to determine (with Panel Delphi Focus Group and AHP) and **EVA protocol** for selecting the initial values form inventory values) and weighting a value-based innovation inventory, according to the sector.

The Rodríguez-Bravo (*et al.*, 2013) model as a process to select and weighting a value-based innovation inventory, according to the division, or department of the firm or corporate organization.

Finally, this conceptual model is considered important and ready to be applied in any sector of the industry interested in the values-based innovation management, due its flexibility, simplicity and broad scope to measure the performance of the firm or corporate organization not only in the economic value but in the general perception of value in all the involved parties.



## References

- Abbott, G.N., White, F.A. and Charles, M.A. (2005). Linking values and organizational commitment: a correlational and experimental investigation in two organizations. *Journal of Occupational and Organizational Psychology*. Vol. 78, pp. 531-51.
- Agle, B.R. and Caldwell, C.B. (1999). Understanding Research on Values in Business: A Level of Analysis Framework. *Business & Society*, Vol. 38, No. 3, pp.326–387.
- Alejos, C.L. (2015). La Innovación Responsable: Creación al Servicios de Todos. Cuadernos de la Cátedra “La Caixa” de Responsabilidad Social de la Empresa y Gobierno Corporativo.España: IESE Business School. Universidad de Navarra: España
- AlgarTech Website, Algartech Values (2017). Ver: <http://algartech.com/es/la-empresa/quienes-somos/>
- Allarakhia, M. Kilgour, D. M. Fuller, J. D. (2010). Modelling the incentive to participate in open source biopharmaceutical innovation. *R&D Management*. Jan. Vol. 40, No. 1, pp. 50-66.
- Almquist,E.; Senior, J. and Bloch, N. (2016). Elements of value. Measuring and delivering what costumers really want.*Harvard Business Review*,September. pp. 3-9.
- Alphabet Website,Google Code of Conduct (2017). See: <https://abc.xyz/investor/other/google-code-of-conduct.html>
- Amazon. Amazon’s 14 Leadership Principles via Jeff Bezos (2017). See: <https://www.youtube.com/watch?v=B-xdfQv3I1k>
- Amdocs Website, Amdocs People and Values (2017). See: <https://www.amdocs.com/our-people-and-values>
- Amazon (2017). See: <https://www.amazon.jobs/working/working-amazon>
- Aravind Eye Care System Portal (2018). See: <http://www.aravind.org/>

- Argyris, C. and Schön, D.A. (1978). *Organizational Learning*. Addison-Wesley: Boston, MA.
- Asakawa, K. Nakamura, H. Sawada, N.(2010), “ Firms’ open innovation policies, laboratories’ external collaborations, and laboratories’ R&D performance”. *R&D Management*. Mar. Vol. 40. No.2, pp. 109-123.
- Autio, E. and Thomas, LL. D. W. (2014). *Innovation Ecosystems: Implications for Innovation Management*. The Oxford Handbook of Innovation Management. Oxford: Oxford University Press.
- AUSG (Australian Government). Core values (2017). See: <https://innovation.govspace.gov.au/innovation-values>
- Avantec Website, Avantec values (2017). See:<http://www.avantec.com.mx/somos.html>
- BBVA (Banco Bilbao Vizcaya) Website, BBVA Principles and Values (2017). See: <http://shareholdersandinvestors.bbva.com/TLBB/micros/bbva2012/en/Executivesummary/Principlesandvalues.html>
- Bimbo Website, Bimbo Valores (2017). See: <http://www.bimbo.es/bimbo/mision-vision-valores>
- Bitam Website, Bitam Values (2017). See; <https://www.bitam.com/nosotros/>
- Bocken, N., Short, S., Padmakshi, R. and Evans, S. (2013) ‘A value mapping tool for sustainable business modelling’, *Corporate Governance: The International Journal of Business in Society*, Vol. 13, No. 5, pp.482–497.
- Bosch Website, Bosch Values (2017). See: [http://www.bosch.com.mx/es/mx/sustainability\\_innovation\\_3/values\\_3/values-landingpage.html](http://www.bosch.com.mx/es/mx/sustainability_innovation_3/values_3/values-landingpage.html)
- Bleicher, K. (1994). *Integrative Management in a Time of Transformation*. *Long Range Planning*, Vol. 27, No. 5, pp.136–144.
- Bleicher, K. (2011). *The Integrated Management Concept*. 8th Edition. Campus:Frankfurt am Main.
- BrandFinance, Website, España 100, 2017. Informe anual de las marcas españolas más valiosas en todo el Mundo(2017). See: [http://brandfinance.com/images/upload/brand\\_finance\\_spain\\_100\\_2017\\_locke1 d.pdf](http://brandfinance.com/images/upload/brand_finance_spain_100_2017_locke1 d.pdf)
- Breuer, H. (2013). *Lean Venturing. Learning to Create New Business through Exploration, Elaboration, Evaluation, Experimentation and Evolution*. *International Journal of Innovation Management*. Vol. 17, No. 5. See: <http://dx.doi.org/10.1142/S1363919613400136>

- Breuer, H. and Lüdeke-Freund (2015). Values-Based Innovation Framework – Innovating by What We Care About. Budapest: The XXVI ISPIM Conference – Shaping the Frontiers of Innovation Management, Budapest, Hungary on 14-17 June 2015.
- Bruno, L.F.C.(2010). The Impact of Organizational Culture on Innovation Management, E-Leader Budapest. See: <http://acervo.ci.fdc.org.br/AcervoDigital/Artigos%20FDC/Artigos%20FDC%202010/Impact%20of%20organizational%20culture.pdf>
- Bruzelius, L.H. and Skärvad P-H (1989). *Integrerad organisationslära*. See: <https://cnicamsysdeli.firebaseio.com/263184328337830.pdf>
- Buchko, A. (2007). The effect of leadership on values-based management. *Leadership & Organization Development Journal*, Vol. 28 No. 1, pp. 36-50.
- Buckland H. and Murillo, D. (2014). *La Innovación Social en América Latina. Socialab. Impulsando la creatividad para luchar contra la pobreza*. ESADE. Instituto de Innovación Social. Universidad Ramón Lull y Fondo Multilateral de Inversiones. Miembro del Grupo BID: España.
- CEMEX (Cementos Mexicanos) Website, Valores de CEMEX, 2017. See: <http://archive.cemex.com/ES/AcercaCemex/Valores.aspx>
- Charter, M. and Clark, T. (2007). *Sustainable Innovation. Key conclusions from Sustainable Innovation Conferences 2003–2006 organised by The Centre for Sustainable Design*. UK: The Centre for Sustainable Design University College for the Creative Arts
- Chesbrough, H. W. (2003). The Era of Open Innovation., *MIT Sloan Management Review*, Vol. 44, No. 3, pp.35–41.
- Chesbrough, H. W. (2006). *Open Business Models: How to Thrive in the New Innovation Landscape*. Boston, MA: Harvard Business School Press. 250 pp.
- Chesbrough Henry W. (2007). Why Companies Should Have Open Business Models. *MIT Sloan Management Review*. Winter 2007. 48 (2), 22-28.
- Chesbrough, H. and Bogers, M. (2014). Explicating open innovation: Clarifying an emerging paradigm for understanding innovation, in H. Chesbrough, W. Vanhaverbeke, & J. West (Eds.), *New Frontiers in Open Innovation*: pp.3-28. Oxford University Press. Oxford
- Chien-Tzu, T. and Wan-Fen, L. (2014). A Framework for Open Innovation Assessment. *International Journal of Innovation Management*. Oct., 18 (5), 100-128.

- Chilova, M.; Iglesias, M.; Navarro, C. and Rodríguez E. (2012). *Aprendiendo de las Empresas Sociales. Seis casos de emprendimientos sociales en Europa*. ESADE. Instituto de Innovación Social. Universidad Ramón Lull: España.
- Corona, Website, Ética y Valores (2017). Ver: <http://www.corona.co/nuestra-empresa/quienes-somos/etica-y-valores>
- Covey, S. R. (1989). *The Seven Habits of Highly Effective People. Powerful Lessons in Personal Change*. Simon & Schuster: London.
- Covey, S.R. (1990). *Principle Centered Leadership*. Simon & Schuster: New York.
- Deloitte. (2015). *Executing an Open Innovation Model: Cooperation is a Key to Competition for Biopharmaceutical Companies*. Deloitte Development LLC. USA.
- Dolan, S.L., Garcia, S. and Auerbach, A. (2003). Understanding and managing chaos in organisations. *International Journal of Management*. Vol. 20, No. 1, pp. 23-35.
- Dolan, S.L. and Richley, B.A. (2006). Managing by values (MBV): a new philosophy for a new economic order. *Handbook of Business Strategy*. Vol. 7, No. 1, pp. 235-8.
- Edgeman, R.L. and Scherer, F. (1999). Systemic leadership via core value Deployment. *Leadership & Organization Development Journal*. Vol. 20, No. 2, pp. 94-8.
- Ecodex Website, Ecodex Values (2017). See: <https://ecodex.com.mx/quienes-somos.html>
- Evolutel Website, Evolutel Values, 2017. See: <http://www.evolutel.com.mx/>
- El Economista Website, Las 20 mejores empresas del mundo en el 2017 (2017a). See: <http://eleconomista.com.mx/industria-global/2017/06/28/las-20-mejores-empresas-mundo-2017>
- El Economista Website, ¿Cuáles son las marcas más valiosas de México? (2017b). See: <http://eleconomista.com.mx/industrias/2017/04/26/cuales-son-las-marcas-mas-valiosas-mexico>
- Facebook, Facebook's 5 core values - explained via Mark Zuckerberg & Sheryl Sandberg, 2017. See: <https://www.youtube.com/watch?v=FMREoPHJKnc>
- Fiedler, F. E. (1967). *A Theory of Leadership Effectiveness*. McGraw-Hill Book Co: New York.
- Finegan, J.E. (2000). The impact of person and organizational values on organizational commitment. *Journal of Occupational and Organizational Psychology*. Vol. 73, pp. 149-69.

- Frankfurt, H.G. (1988). *The importance of what we care about. Philosophical essays*. Cambridge University Press: New York, USA.
- Graeber, D. (2001) *Toward an anthropological theory of value: A false coin of our dreams*. Palgrave, New York.
- Gassman, O. Enkel, E. (2004). *Towards a Theory of Open Innovation: Three Core Process Archetypes*. 2-18. See: [https://www.alexandria.unisg.ch/274/1/Gassmann\\_Enkel.pdf](https://www.alexandria.unisg.ch/274/1/Gassmann_Enkel.pdf)
- Gassmann, O. Enkel, E. Chesbrough, H. (2010). The Future of Open Innovation. *R&D Management*, Jun. Vol. 40, No. 3, pp. 213-221.
- Goglio-Primard, K. Crespín –Mazet, F. (2014). Organizing Open Innovation in Networks. The role of boundary relations. *Management international*. Vol. 9, pp. 135-147.
- Griseri, P. (1998). *Managing Values. Ethical Change in Organisations*. Macmillan Press: Basingstoke.
- Guth, W. T. and TAGIURI, R. (1965). Personal Values and Corporate Strategies. *Harvard Business Review*, September – October, pp. 126.
- Hansen, E.G., Große-Dunker, F. and Reichwald, R. (2009). Sustainability Innovation Cube - A Framework to Evaluate Sustainability-Oriented Innovations, *International Journal of Innovation Management*, Vol. 13, No. 4, pp.683–713.
- Hernández-Ascanio, J.; Tirado-Valencia, P. and Ariza-Montes (2016). El concepto de innovación social: ámbitos, definiciones y alcances teóricos. *Revista de Economía Pública, Social y Cooperativa*, 88, Diciembre 2016, pp. 165-199.
- Hofstede, G., Neuijen, B., Ohayv, D.D. and Sanders, G. (1990). Measuring organizational cultures: a qualitative and quantitative study across 20 cases. *Administrative Science Quarterly*. Vol. 35 No. 2, pp. 286-316.
- Hughes, B. & Wareham, J. (2010), Knowledge arbitrage in global pharma: a synthetic view of absorptive capacity and open innovation, *R&D Management*, Jun. Vol. 40, No. 3, pp. 324-343.
- Interbrand (2017). Best Global Brandings. See: <http://interbrand.com/best-brands/best-global-brands/2017/ranking/>
- Jaakson, K. (2010). Management by values: are some values better than others? *Journal of Management Development*. Vol. 29, No. 9, pp. 795-806.
- Jehn, K.A. (1994). Enhancing effectiveness: an investigation of advantages and disadvantages of value-based intragroup conflict. *The International Journal of Conflict Management*. Vol. 5, No. 3, pp. 223-38.

- Joas, H. (2000) *The genesis of values*. Polity: Cambridge, England.
- Jones, P.H. (2002) 'Embedded Values in Process and Practice: Interactions Between Disciplinary Practices and Formal Innovation Processes', *Design Management Journal - Academic Review*, Vol. 2, No. 1, pp.20–36.
- Keup, M.M; Gassmann, O.(2009).Determinants and archetype users of open Innovation. *R&D Management*, Sep, Vol. 39,No. 39 (4), pp.331-341.
- Kotter, J.P. and Heskett, J.L. (2011) .*Corporate Culture and Performance*. The Free Press: New York.
- LAICOM (Laboratory of Instrumental Analysis of the Communication), Laboratorio de Análisis Instrumental de la Comunicación (2017). See: <http://www.uab.cat/web/laicom-1274251163063.html>
- Lencioni, P.M. (2002). Make your values mean something. *Harvard Business Review*, July, pp. 113-17: New York.
- Lichtenthaler, U.(2009). Outbound open innovation and its effect on firm performance: examining environmental influences. *R&D Management*, Sep, Vol. 39, No.4, pp. 317-330.
- Longman (2017). *Dictionary of Contemporary English*. Longman Group Ltd: London.
- Luck, E. J. and oliver, Bruce l. (1974). American Managers' Personal Value System – Revisited. *Academy of Management Journal*, September, pp. 549 – 554.
- Maitland Website, The values most valued by UK plc. (2015). See: <http://www.maitland.co.uk/wp-content/uploads/2015/10/20151001-Maitland-Values-Report.pdf>
- Mas-Manchón, Ll. ; Rodríguez-Bravo, A.; Montoya-Vilar,N.; Morales-Morante, F.; Lopez, El.; Añañanos, E. Pers, R.; Marínez, M.E.; Grau A. (2015)Valores percibidos en la publicidad de alimentos por jóvenes con y sin trastornos de la conducta alimentaria. *Salud Colectiva*, [S.l.], v. 11, n. 3, p. 423-444, sep. 2015. ISSN 1851-8265. <http://dx.doi.org/10.18294/sc.2015.729>
- Mas-Manchón,Ll., Rodríguez-Bravo, A.; Montoya-Vilar,N.; Morales-Morante, F.; Lopez, E.; Wilson-Salgado, A. (2016) Values Perception in Food Comercias with Dietary Strategies. *Prisma social*. N° Especial 1, mayo 2016. *Revista de ciencias sociales*. ISSN: 1989-3469. [http://www.isdfundacion.org/publicaciones/revista/numeros/N\\_Especial%201/secciones/tematica/2\\_nespecial\\_values-perception.html](http://www.isdfundacion.org/publicaciones/revista/numeros/N_Especial%201/secciones/tematica/2_nespecial_values-perception.html)
- Mejía-Trejo, J.; Sanchez-Gutierrez and J. Ortiz-Barrera, A. (2013). Leadership and Value Creation on Innovation: The Case of

- Software Developer Sector in Guadalajara México. *Competition Forum*. Vol.11 , No. 1, pp.24-31.
- Mejía-Trejo, J. (2017a). The determinant factors of open business model. De *Nova Scientia*:<http://novascientia.delasalle.edu.mx/ojs/index.php/Nova/article/view/710/334>
- Mejía-Trejo, J. (2017b). Digital Broadband and Open Innovation: First Insights in Information Technologies Sector. De *Revista del Centro de Investigación de la Universidad La Salle*. See: <http://dx.doi.org/10.26457/recein.v13i47.1146>
- Mejía-Trejo, J. (2017c). The values-based innovation in the organization. working on a competitive concept. first insights in mexico using the panel delphi focus group and AHP method. *Journal of International Business and Economics*. Vol.17, No. 4, p37-52, December 2017 See [https://papers.ssrn.com/sol3/papers.cfm?abstract\\_id=3134210](https://papers.ssrn.com/sol3/papers.cfm?abstract_id=3134210)
- Microsoft Website, What We Value (2017). See: <https://www.microsoft.com/en-us/about/values>
- Milenio (2014) *Prohiben circos con animales silvestres*. See: [http://www.milenio.com/df/Prohiben-circos-animales-silvestres\\_0\\_425957432.html](http://www.milenio.com/df/Prohiben-circos-animales-silvestres_0_425957432.html)
- Miller, K.; Puthusserry, P.; McAdam, R.; Moffett, S.and Alexander, A. (2016), Knowledge transfer in university quadruple helix ecosystems: an absorptive capacity perspective. *R&D Management*, Mar. Vol.46, No. 2, pp. 383-399.
- Maccoby, M. (1998). Making values work. *Research: Technology and Management*, September-October, pp. 55-7.
- Mowles, C. (2008). Values in international development organizations: negotiating non-negotiables. *Development in Practice*. Vol. 18 No. 1, pp. 5-16.
- Nanus, B. (1995). *Visionary Leadership: Creating a Compelling Sense of Direction for Your Organization*. Jossey-Bass Publishers :San Francisco, CA.
- Nasoft Website, Nasoft Values (2017). See: <http://www.agsnasoft.com/es/valores.php>
- OECD Organisation for Economic Cooperation and Development, (2001). *Measuring productivity oecd manual measurement of aggregate and industry-level productivity growth*. Organisation for Economic Cooperation and Development Publishing. 156 pp: France
- OECD, Organisation for Economic Cooperation and Development (2003). *Knowledge Management. Measuring Knowledge Management*

- in the Business Sector. First Steps.* Organisation for Economic Cooperation and Development Publishing. 216 pp: France
- OECD, Organisation for Economic Cooperation and Development (2005). *Oslo Manual: Guidelines for Collecting and Interpreting Innovation Data*, 3rd Edition Organisation for Economic Cooperation and Development Publishing.166 pp: France
- OECD, (2008) Organisation for Economic Co-operation and Development. *Open Innovation in Global Networks.* Organisation for Economic Cooperation and Development Publishing Publishing:France.
- Osgood, C.; Suci, G.; Tannenbaum, P.(1957) *The measurement of meaning.* University of Illinois Press.
- Osterwalder, A. and Pigneur, T. (2010). *Business Model Generation.* Hoboken. New Jersey: John Wiley y Sons, Inc., Hoboken, New Jersey.
- Oxxo Website, Oxxo: Misión, Visión y Valores (2017). See: <http://www.oxxo.com/quienes-somos/valores-mision-y-vision.htm>
- Owen, R., Bessant, J. and Heintz, M. (2013). *Responsible innovation. Managing the responsible emergence of science and innovation in society*, Wiley: Chichester.
- Pant, P.N. and Lachman, R. (1998). Value incongruity and strategic choice. *Journal of Management Studies.* Vol. 35, No. 2, pp. 195-212.
- Peters, T.J. and Waterman, R.H. (1982). *In Search of Excellence: Lessons from America's Best-run Companies.* Harper & Row: New York, NY.
- Peterson, M.F. (2004). Culture, leadership and organizations: the GLOBE study of 62 Societies. *Administrative Science Quarterly.* Vol. 49 No. 4, pp. 641-7.
- Prahalad, C.K. (2005) *La fortuna en la base de la pirámide: un modelo de negocio rentable, que sirve a las comunidades más pobres.* Ed. Granica: España.
- Prilleltensky, I. (2000).Value-based leadership in organizations: balancing values, interests, and power among citizens, workers, and leaders. *Ethics & Behavior.* Vol. 10 , No. 2, pp. 139-58.
- Qualtop Website, Qualtop Values, 2017. See: <http://www.qualtop.com/pages/about-us>
- Quantum Website,Centro de Software. QSW Valores (2017). See: <http://www.centrodelsoftware.com.mx/conocenos/#valores>
- Rayna, T.and Striukova,L. (2014). Open Innovation 2.0: Is co-creation the ultimate challenge?. *International Journal of Technology Management.*Vol.69, No.1, pp.100-118



- Remneland-Wikhamn, B and Knights, D. (2012). Transaction Cost Economics and Open Innovation: Implications for Theory and Practice. *Creativity and Innovation Management*. Vol.21, No.3, pp. 277-289.
- Rittel, H.W. and Webber, M.M. (1973). Dilemmas in a General Theory of Planning, *Policy Sciences*, Vol. 4, No. 2, pp.155–169
- Robu, B. and Ciora, C. (2008). Measuring performance, value creation and value-based management in the context of competitiveness and globalization. See: [https://www.researchgate.net/publication/227359036\\_MEASURING\\_PERFORMANCE\\_VALUE\\_CREATION\\_AND\\_VALUE-BASED\\_MANAGEMENT\\_IN\\_THE\\_CONTEXT\\_OF\\_COMPETITIVENESS\\_AND\\_GLOBALIZATION](https://www.researchgate.net/publication/227359036_MEASURING_PERFORMANCE_VALUE_CREATION_AND_VALUE-BASED_MANAGEMENT_IN_THE_CONTEXT_OF_COMPETITIVENESS_AND_GLOBALIZATION)
- Rodríguez-Bravo, A.; Montoya-Vilar, N.; Mas, L. Y Muller, K. (2013). A. Evaluation and measuring of values in audiovisual contents from an interdisciplinary approach. *Primasocial. Revista de investigación Social*. No. 11, December. See: [https://www.researchgate.net/publication/292376171\\_Evaluation\\_and\\_measuring\\_of\\_values\\_in\\_audiovisual\\_contents\\_from\\_an\\_interdisciplinary\\_approach](https://www.researchgate.net/publication/292376171_Evaluation_and_measuring_of_values_in_audiovisual_contents_from_an_interdisciplinary_approach)
- Roe, R.A. and Ester, P. (1999). Values and work: empirical findings and theoretical Perspectives. *Applied Psychology: An International Review*, Vol. 48 No. 1, pp. 1-21.
- Rubino, J.A. (1998). Aligning personal values and corporate values: a personal and strategic necessity. *Employment Relations Today*. Vol. 25, No. 3, pp. 23-35.
- Santander Website, Santander Values (2017). See: [https://www.santander.com/csgs/Satellite/CFWCSancomQP01/en\\_GB/Corporate/Values.html](https://www.santander.com/csgs/Satellite/CFWCSancomQP01/en_GB/Corporate/Values.html)
- Schein, E.H. (2004). *Organizational Culture and Leadership*. 3rd ed. Jossey-Bass: San Francisco, CA.
- Schrage, M. (2012) *Who Do You Want Your Customers to Become?*, Harvard Business Review Press, Boston, MA.
- Schwartz, S.H. (2012). An Overview of the Schwartz Theory of Basic Values, *Online Readings in Psychology and Culture*, Vol. 2, No. 1,
- Speculand, R. and Chaudhary, R. (2008). Living organisational values: the bridges value inculcation model. *Business Strategy Series*. Vol. 9, No. 6, pp. 324-9.
- Spranger, E. (1928). *Types of Men*. Halle Max Niemeyer, Verlag: Germany Stackman, R.W., Pinder, C.C. and Connor, P.E. (2000). Values lost. Redirecting research on values in the workplace. in *Ashkanasy, N.M., Wilderom, C.P.M. and Peterson, M.F. (Eds)*,

- Handbook of Organizational Culture & Climate*. pp. 37-54 Sage Publications: London.
- Susskind, L. and Rose, A.Z. (2010). How to Negotiate When Values are at Stake, *Negotiation MIT*, Vol. 13 No.10, pp. 1-4.
- Ruckenstein, M.; Suikkanen, J.; Tamminen, S. (2011). *Forget innovation. Focus on Value Creation. Success stories in human-centred innovation or how to create a new kind of value*. Edita Publishing: Helsinki.
- Strickland, R.A. and Vaughan, S.K. (2008). The hierarchy of ethical values in non-profit organizations. *Public Integrity*. Vol. 10, No. 3, pp. 233-51.
- Tannenbaum, R. and Schmidt, W. (1958) How to Choose a Leadership Pattern. *Harvard Business Review*, March – April, pp. 95-102
- Televisa.news (2018) Animales de circo tienen destino incierto tras ley que prohíbe su uso en espectáculos. See: <https://noticieros.televisa.com/ultimas-noticias/animales-circo-tienen-destino-incierto-ley-que-prohibe-espectaculos/>
- Telmex Website, Código de Ética (2017). See: <https://downloads.telmex.com/pdf/codigoetica.pdf>
- Thomsen, S. (2004). Corporate values and corporate governance. *Corporate Governance*. Vol. 4, No. 4, pp. 29-46.
- Van der Wal, Z. and Huberts, L. (2007). Value solidity in government and business: results of an empirical study of public and private sector organizational values. *The American Review of Public Administration*, Vol. XX No. X, pp. 1-22.
- Waddock, S. and Rasche, A. (2012) *Building the Responsible Enterprise. Where Vision and Values Add Value*. Business Books: Stanford.
- Waddock, S. (2013). The Wicked Problems of Global Sustainability Need Wicked (Good) Leaders and Wicked (Good) Collaborative Solutions. *Journal of Management for Global Sustainability*, Vol. 1, No. 1, pp.91–111.
- West, J. & Bogers, M. (2014). Leveraging External Sources of Innovation: A Review of Research on Open Innovation. *Journal of Product Innovation Management* Vol. 31, No. 4, pp. 814–831.
- Wandahl, S. (2002). Værdibaseret samarbejde - processtyring skaber højere produktværdier for alle (Value-Based Cooperation - process controls gains higher product value for everybody). M.sc.- thesis, Department of Production, Aalborg University.
- Wandahl, S. and Bejder, E. (2003). *Value-Based Management in the Supply Chain of Construction Projects*. The 11th annual conference on Lean Construction, Blacksburg. Edt.: Martinez and Formoso

- Wandahl, S. (2004). *Value-Based Management as means for increasing effectiveness and efficiency in construction projects*. See: <http://www.irbnet.de/daten/iconda/CIB1523.pdf>
- Wenstop, F.A. and Myrmel, A. (2006). Structuring organizational value statements. *Management Research News*. Vol. 29, No. 11, pp. 673-83.
- Zara Website. *Zara's Historical Background and Marketing Strategy* (2017). See: <https://www.slideshare.net/JiYoungLee26/final-zara-marketing-strategy>

## Acerca de los autores

### *Juan Mejía Trejo*

He was born in Mexico City in 1964, he worked as Exploitation Internal Plant Manager (1987-2008) at Western Division of Teléfonos de México, SAB (Telmex). He is an Engineer in Communications and Electronics (1992) from the School of Mechanical and Electrical Engineering (ESIME) of the National Polytechnic Institute (IPN). He is Master of Business Administration in Telecommunications (2000) by Technological Institute of Teléfonos de Mexico (Inttelmex), earned his Doctorate in Administrative Sciences (2010), by the Superior School of Commerce and Administration (ESCA) of the National Polytechnical Institute (IPN). He has been a visiting professor at various institutions of higher education in the metropolitan area of Guadalajara, Jalisco, such as UNITEC, UVM, ITESO, UP, UAG and UTZMG.

Since 2010, he collaborates as a research professor at the Department of Marketing and International Business of the University Center of Economic and Administrative Sciences (CUCEA) at the University of Guadalajara (UdeG), also holding the Presidency of the Electronic Business Academy as well as the Coordination of the Doctorate in Administration Sciences. He has given seminars, workshops and conferences around his main lines of research: Administration of Innovation in Digital Marketing and Electronic Business. Since 2011, he is a member of the National System of Researchers (SNI) Level II, of the National Council of

Science and Technology (CONACYT) of Mexico, having written more than 60 works amongst articles, chapters of books and books about his principal lines of research, all available on the Social Sciences Research Network portal (<https://www.ssrn.com/en/>)

### **Ángel Rodríguez Bravo**

He was born in Vilanova i La Geltrú (Barcelona) in 1956, he was graduated (1982) and earned his Phd in Information Sciences (1989) by the Autonomous University of Barcelona UAB. He is a researcher profesor at UAB since 1991. He received, from the Catalanian government the IV Award of Mass communication (1991). He is founder and director of the Laboratory of Instrumental Analysis of Communication (LAICOM) since 1993. He is the autor (and co-author) of several scientific publications (more than 70), including: *La dimensión sonora del lenguaje audiovisual* published in spanish (2001) and portuguese (2006); *Propuestas para una modelización del uso expresivo de la voz* (2002); *La investigación aplicada: una nueva perspectiva para los estudios de recepción* (2003); *Narrativas radiofónicas: ritmos duraciones y arquitecturas sonoras* (2011); *Valores percibidos en la publicidad de alimentos por jóvenes con y sin trastornos de la conducta alimentaria* (2015); *Investigación aplicada, comunicación corporativa y valor agregado. Método para el planteamiento y la solución de problemas* (2015); *Medición y evaluación de valores en contenidos audiovisuales desde un abordaje interdisciplinar* (2013) and *Values perception in food commercials with dietary strategies* (2016).

He has participated in 12 R+Di projects, the last being: *Protocolo para la Medición y Evaluación de Valores en Contenidos Audiovisuales*, (CSO2012-33170), funded by the Spanish Ministry of Economy and Competitiveness. He got a patent called: *Evaluation and measuring values software* supported by LAICOM group. He has been a visitor researcher profesor at 13

universities. Currently, he coordinates the doctoral program in strategic communication, publicity and public relationships at Autonomus University of Barcelona

*Values-Based Innovation  
Designing a Model to be applied  
in Management Sciences*

se terminó de imprimir en agosto de 2019  
en los talleres de Ediciones de la Noche  
Madero #687, Zona Centro Guadalajara, Jalisco

El tiraje fue de 500 ejemplares

[www.edicionesdelanoche.com](http://www.edicionesdelanoche.com)

**V**alues and innovation are two novel elements in the development of organizations. These elements allow us to align innovation with the values of senior management and its collaborators to achieve a high performance of human, technical and financial resources in all kinds of organizations. The impact increases significantly when a process of evaluation is applied to specific values such as the EVA protocol (designed in the Autonomous University of Barcelona, UAB). Thus, this work aims to introduce the reader to the design of a complex-model proposal based on the interaction of both the values-based innovation construct for specific-area needs, and the EVA protocol, in order to improve the innovation process.



Universidad de Guadalajara  
Centro Universitario de Ciencias  
Económico Administrativas

**UAB**

Universitat Autònoma de Barcelona

ISBN 978-84-17840-36-5



9 788417 840365



Libro científico que presenta:

1. Acceso universal al conocimiento a través del Portal de productividad docente Doctorado en Ciencias de la Administración (DCA) de la Universidad de Guadalajara (UdeG):

[http://dca.cucea.udg.mx/sites/default/files/adjuntos/2019\\_values-based\\_innovation\\_designing\\_a\\_model\\_to\\_be\\_applied\\_in\\_management\\_sciences.pdf](http://dca.cucea.udg.mx/sites/default/files/adjuntos/2019_values-based_innovation_designing_a_model_to_be_applied_in_management_sciences.pdf)

2. Reconocimiento del Consejo Superior de investigaciones Científicas (CSIC, España) a la editorial de la Universidad de Guadalajara como nivel Alto.

[https://glosariobibliotecas.files.wordpress.com/2020/05/ie-csic\\_2018.pdf](https://glosariobibliotecas.files.wordpress.com/2020/05/ie-csic_2018.pdf)

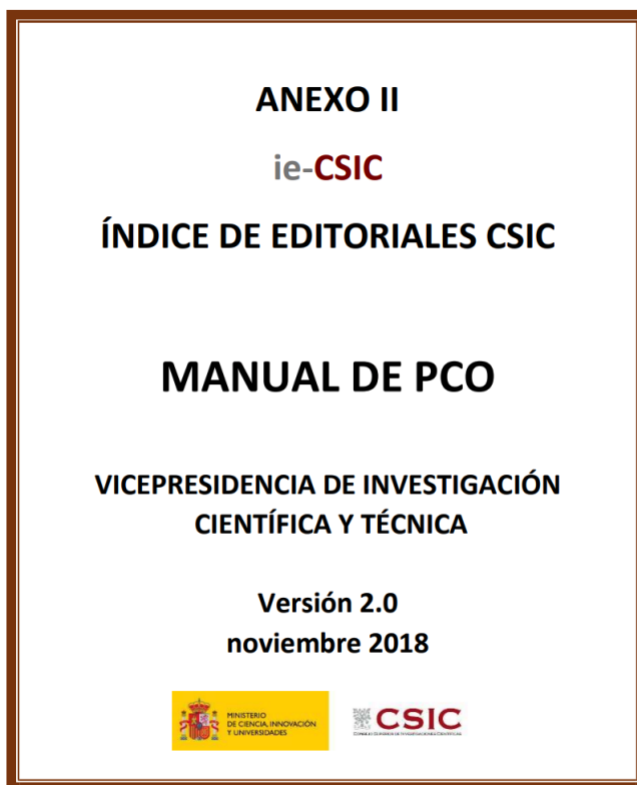

Universidad de Extremadura	MEDIO
Universidad de Guadalajara México	ALTO
Universidad de Guanajuato	BAJO
Universidad de Jaén	MEDIO

2. Constancias de dictámenes de la evaluación por pares académicos a doble ciego, a las que fue sometida la obra basada en el Reglamento para Producción Editorial de la Evaluación de la obras, de la Universidad de Guadalajara.

3. Reconocimientos de participación como evaluadores y dictaminadores de la obra.



A quien corresponda:

Por medio de la presente se hace constar que de acuerdo con los registros de esta Secretaría Académica, la obra titulada:

**“Values-Based Innovation. Designing a Model to be Applied in Management Sciences.”**

ISBN 978-84-17840-36-5

Coordinadores editoriales: Juan Mejía Trejo y Ángel Rodríguez Bravo

Se publicó en el año 2019, por contar con los elementos teóricos, metodológicos, técnicos y de redacción de acuerdo con los resultados de la evaluación por pares académicos a doble ciego a la que fue sometida la obra, esto de conformidad en con lo establecido en el Reglamento para la Producción Editorial de este Centro Universitario, en su Título Tercero, De la evaluación de las Obras, Artículo 9, incisos a y b.

Se extiende la presente para los fines que al interesado convenga.

Atentamente

**“Piensa y Trabaja”**

Zapopan, Jal., 10 de diciembre de 2019

  
**Dr. José María Nava Preciado**

Secretario Académico





UNIVERSIDAD DE GUADALAJARA

CENTRO UNIVERSITARIO DE CIENCIAS ECONÓMICO ADMINISTRATIVAS  
SECRETARÍA ACADÉMICA

A quien corresponda:

Por medio de la presente, el Centro Universitario de Ciencias Económico Administrativas a través de su Secretaría Académica agradece a:

**ÁLVARO PEDROZA ZAPATA**

Por su participación como evaluador y dictaminador del trabajo de investigación propuesto para su publicación titulado **“Values-Based Innovation. Designing a Model to be Applied in Management Sciences”**, en conformidad con lo establecido en el Reglamento para la Producción Editorial de este Centro Universitario, en su Título Tercero, Artículo 9.

Se extiende la presente para los fines que al interesado convenga.

Atentamente

**“Piensa y Trabaja”**

**“Año de la transición energética de la Universidad de Guadalajara”**

Zapopan, Jal., 10 de diciembre de 2020

  
**Dr. José María Nava Preciado**

Secretario Académico





UNIVERSIDAD DE GUADALAJARA

CENTRO UNIVERSITARIO DE CIENCIAS ECONÓMICO ADMINISTRATIVAS  
SECRETARÍA ACADÉMICA

A quien corresponda:

Por medio de la presente, el Centro Universitario de Ciencias Económico Administrativas a través de su Secretaría Académica agradece a:

**CARLOS OMAR AGUILAR NAVARRO**

Por su participación como evaluador y dictaminador del trabajo de investigación propuesto para su publicación titulado **“Values-Based Innovation. Designing a Model to be Applied in Management Sciences”**, en conformidad con lo establecido en el Reglamento para la Producción Editorial de este Centro Universitario, en su Título Tercero, Artículo 9.

Se extiende la presente para los fines que al interesado convenga.

Atentamente

**“Piensa y Trabaja”**

**“Año de la transición energética de la Universidad de Guadalajara”**

Zapopan, Jal., 10 de diciembre de 2020

  
**Dr. José María Nava Preciado**  
Secretario Académico

  
SECRETARÍA ACADÉMICA  
CENTRO UNIVERSITARIO  
DE CIENCIAS  
ECONÓMICO ADMINISTRATIVAS